

Moldes de inyección AUTOMOCIÓN

PRODUCTO: PEUGEOT 408 front bumper (PP) - 1757*643*646 mm

NOMBRE Front bumper mold
SECTOR Automotive
TAMAÑO 2632*1530*1781mm
CAVIDADES 1
MATERIAL German 1.2311 (Cavity&Core)
EYECCIÓN Cylinder
INYECCIÓN Hot runner 9-point valve pin

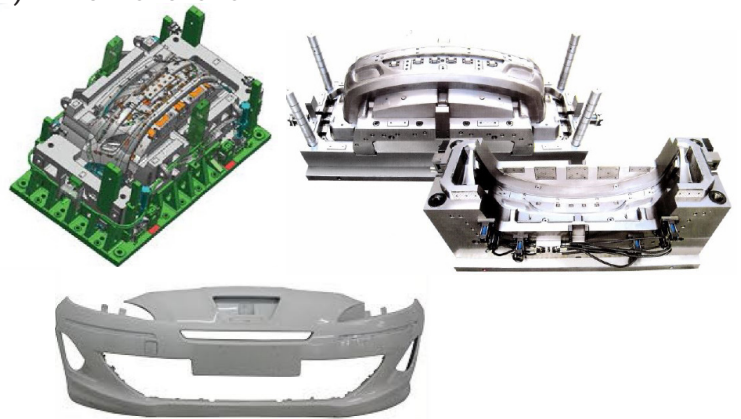

PRODUCTO: MITSUBISHI MOTOR door panel (PPT10) - 950*450*75 mm

NOMBRE Door car panel mold
SECTOR Automotive / Column serie
TAMAÑO 1200x1350x838 mm
PESO 7,9 Tons
CAVIDADES 1
MATERIAL Cavity 718H ; Core: P20
EYECCIÓN Hydraulic cylinder
INYECCIÓN Hot runner 4-point valve pin



PRODUCTO: HONDA radiator holder (PP 40%LGF) - 1483*603*472 mm

NOMBRE Radiator holder mold
SECTOR Automotive
TAMAÑO 2090*1600*1366 mm
PESO 22 Tons
CAVIDADES 1*1
MATERIAL Cavity 1.2711 ; Core: 1.2711
EYECCIÓN Hydraulic ejection
INYECCIÓN Hot runner 5-point valve pin

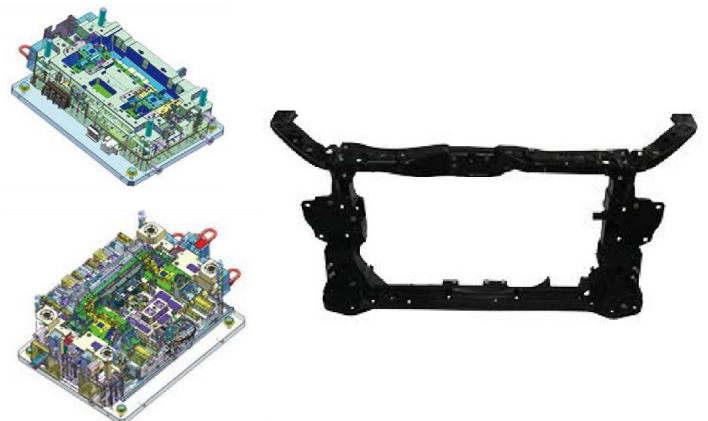

Moldes de inyección

AUTOMOCIÓN

PRODUCTO: NISSAN front radiator grill (PP) - 950*350*170 mm

MOLDE Front radiator grill mold
SECTOR Automotive
TAMAÑO 1450*1050*1030 mm
PESO 8,6 Tons
CAVIDADES 1*1
MATERIAL Cavity 1.2738; Core P20
EYECCIÓN Hydraulic cylinder
INYECCIÓN Hot runner 5 point valve pin

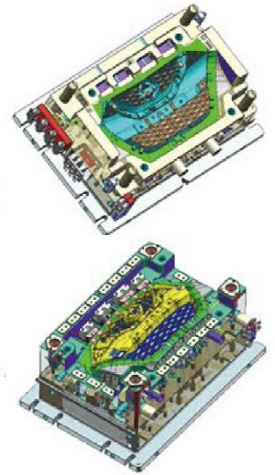

PRODUCTO: PEUGEOT instrument panel (PP) - 1398*588*458 mm

NOMBRE Instrument panel mold
SECTOR Fascia / Instrument panel
TAMAÑO 2700*1620*1600 mm
PESO 31 Tons
CAVIDADES 1
MATERIAL Cavity 1.2738; Core P20
EYECCIÓN Hydraulic cylinder
INYECCIÓN Hot runner 6 point valve pin

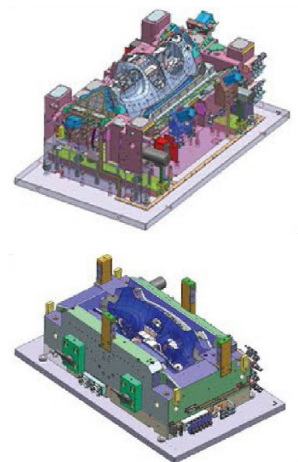

Moldes de inyección AGRICULTURA

PRODUCTO: Knapsack Sprayer Tank Body (PP/ABS)

NOMBRE knapsack Tank Injection mold
SECTOR Agriculture
CAVIDADES 1
MATERIAL P20 prehardened steel
S136 (cavity & core)
INYECCIÓN Cold runner
MOLD RUNNER 500.000 shots

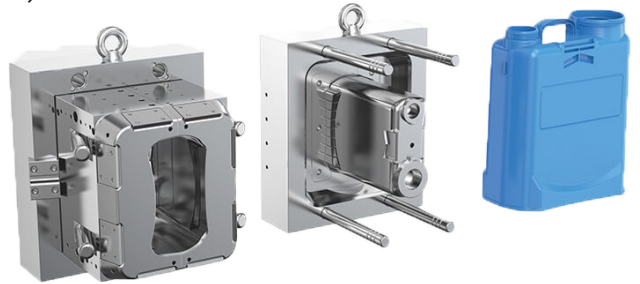

PRODUCTO: Drip pipe connector (PP)

NOMBRE Agriculture drip pipe mold
SECTOR Piping sector
TAMAÑO 490*840*465 mm
PESO 150 Tons
CAVIDADES 16
MATERIAL Stavax S136 HRC45-48 (Core & cavity)
INYECCIÓN 4 tip hot runner point gate

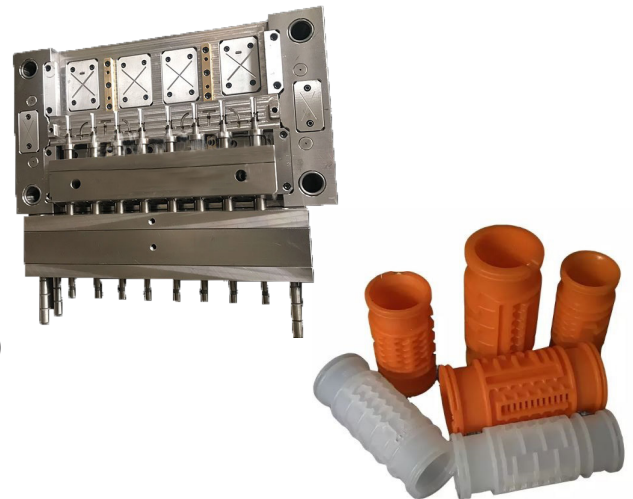

PRODUCTO: Plastic cap (PE)

NOMBRE Bottle cap mold
SECTOR Agriculture
CAVIDADES 4
MATERIAL P20 prehardened steel
S136 HRC46-50 (cavity & core)
INYECCIÓN Hot runner
MOLD RUNNER 1 million



Moldes de inyección CAJAS Y PALLETS

PRODUCTO: Fruit crate (400*300*160 mm)

NOMBRE Plastic crate mold
SECTOR Food industry
TAMAÑO 1520*1202*850 mm
PESO 1200 Tons
CAVIDADES 4
MATERIAL MoldMAX Copper Beryllium + DIN 1.2311
INYECCIÓN 16 points hot nozzle with point gate
EYECCIÓN Stripper plate
CICLO 25 seconds
MOLD RUNNER 5 million, full automatic.
CARACTERÍSTICAS The application of Copper Beryllium leads to best cooling effect.
Hot runner professional filter system design, suitable for high speed recycled material injection production.

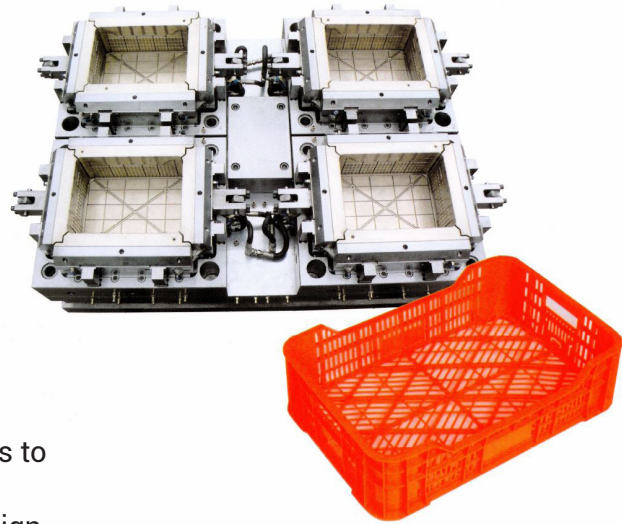

PRODUCTO: Large box (1200*1000*760 mm)

NOMBRE Large size box mold
SECTOR Packaging
TAMAÑO 2250*2450*1800 mm
PESO 3350 Tons
CAVIDADES 1
MATERIAL P20HH
INYECCIÓN Hot runner 21 tips
EYECCIÓN Ejector block
CICLO 180 seconds
MOLD RUNNER 500.000 shots
CARACTERÍSTICAS Fully automatic production line.
Large mold and very special complex molding structure part



Moldes de inyección

CAJAS Y PALLETS

PRODUCTO: Dual-layer pallet (1400*1200*150 mm)

NOMBRE	Pallet mold
SECTOR	Packaging
TAMAÑO	1800*1800*1100 mm
PESO	2250 Tons
CAVIDADES	1
MATERIAL	DIN 1.2311
INYECCIÓN	16 pints hot runner gate
EYECCIÓN	Ejector pin and ejecting block
CICLO	95 seconds
MOLD RUNNER	1 million
CARACTERÍSTICAS	Suitable for high speed recycled material injection production.

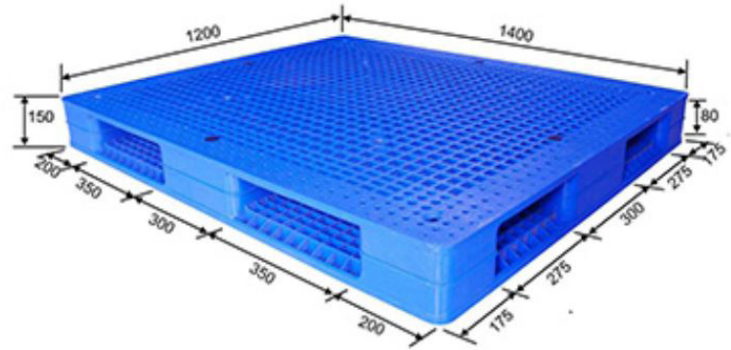

Moldes de inyección MOBILIARIO

PRODUCTO: Rattan plastic chair (580*600*900 mm)

NOMBRE Gas-assisted chair mold
SECTOR Furniture
TAMAÑO 1818*1400*1227 mm
PESO 1650 Tons
CAVIDADES 1
MATERIAL DIN 1.2738
INYECCIÓN Cold runner
EYECCIÓN Ejection pin
CICLO 5 minutes
MOLD RUNNER 1 million
CARACTERÍSTICAS Gas assisted mold



PRODUCTO: Beach chair

NOMBRE Beach chair mold
SECTOR Furniture
TAMAÑO 2800*1450*1320 mm
PESO 550 Tons
CAVIDADES 1
MATERIAL 718H
INYECCIÓN Hot runner 12 tips
EYECCIÓN Ejector pin
CICLO 72 seconds
MOLD RUNNER 500.000 shots
CARACTERÍSTICAS High effect of cooling in mould
Automatic drop in running
Good finish of the chair surface



Moldes de inyección MOBILIARIO

PRODUCTO: Plastic arm chair (1200*750*700 mm)

NOMBRE	Arm Chair Mould
SECTOR	Furniture
TAMAÑO	1350*860*800mm
PESO	850 Tons
CAVIDADES	1
MATERIAL	P20
INYECCIÓN	1-point hot runner direct cone gate
EYECCIÓN	Ejector pin
CICLO	45 seconds
MOLD RUNNER	800.000 shots
CARACTERÍSTICAS	Special design cone gate



PRODUCTO: Plastic chair, rattan surface finish (550*550*850 mm)

NOMBRE	Gas-assisted chair mold
SECTOR	Furniture
TAMAÑO	1400*900*850 mm
PESO	1150 Tons
CAVIDADES	1
MATERIAL	2738H steel
INYECCIÓN	YUDO hot runner
EYECCIÓN	Ejection pin
CICLO	55 sec.
MOLD RUNNER	1 million
CARACTERÍSTICAS	Gas injection mold, transmit pressure uniformly on such smaller machines (Reduce of power consumption), moulded in strees. High precision texture (improved dimensional stability with no distorsion) Thick sections



Moldes de inyección

SANIDAD Y MEDICINA

PRODUCTO: Petri dish

NOMBRE Petri dish mold
SECTOR Medical
PESO 200 Tons
CAVIDADES 2+2 family mold
MATERIAL S136
CICLO 8 seconds
MOLD RUNNER 5 million strokes



PRODUCTO: COVID-19 ANTIGEN SELF TEST (PP)

NOMBRE Self test device mold
SECTOR Medical
CAVIDADES 64 cavities
MATERIAL S136 (main)
INYECCIÓN Yudo point gate
CICLO 10 seconds

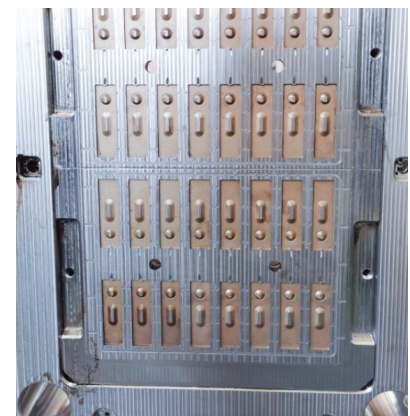

Moldes de inyección

SANIDAD Y MEDICINA

PRODUCTO: Blood collection tube (PET, Ø 12,5*75 mm)

NOMBRE Test tube mold

SECTOR Medical

TAMAÑO 660*500*478 mm

PESO 200 Tons

CAVIDADES 32 cavities

MATERIAL S136 (Cavity & core)

INYECCIÓN 32 tip valve gate

EYECCIÓN Stripper plate

CICLO 12 seconds

MOLD RUNNER 5 million shots

CARACTERÍSTICAS High speed mold.

High transmittance surface without sink mark.

High precision tooling control without eccentricity.



PRODUCTO: Disposable syringe (PP)

NOMBRE Syringe mold

SECTOR Medical

CAVIDADES 64 cavities

MATERIAL Stavax S136 steel

INYECCIÓN Point gate

MOLD RUNNER 5 million shots

CARACTERÍSTICAS Interchangeable inserts

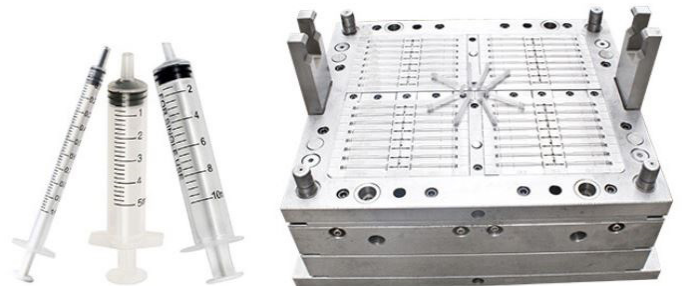

Moldes de inyección

INDUSTRIAL

PRODUCTO: Motor POM gear (35,5*35,5*21,5 mm)

NOMBRE High precision gear mold
TAMAÑO 388*361*450 mm
MATERIAL Steel 8407
INYECCIÓN 3-plate point gate
EYECCIÓN Ejector pin
CICLO 22 seconds
MOLD RUNNER 500.000 shots
CARACTERÍSTICAS Control of the POM shrinkage and product thickness.
POM product has high rigidity and sound abrasion resistance.



PRODUCTO: White cover, ASA material (124*152*80 mm)

NOMBRE Plastic cover mold
TAMAÑO 600*610*880 mm
PESO 875 Kg
CAVIDADES 2
MATERIAL Steel 2343ESR
MOLD RUNNER Cold runner to sub gate
CARACTERÍSTICAS Hot sprue bushing.
Slider core side.
2343ESR offers good toughness, excellent heat resistance and resistance to wear and thermal shock.

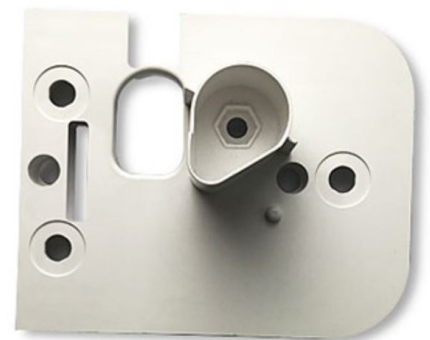

Moldes de inyección

INDUSTRIAL

PRODUCTO: Lawn mower cover (450*700*350 mm)

NOMBRE Plastic lawn mower mold
SECTOR Gardening
TAMAÑO 1200*850*700 mm
PESO 850 Tons
CAVIDADES 1
MATERIAL 2378
INYECCIÓN Hot runner
EYECCIÓN Ejector pin
CICLO 40 seconds
MOLD RUNNER 1 million



Moldes de inyección

JUGUETES

PRODUCTO: Plastic car (PP, 528*500*270 mm)

NOMBRE Toy car mold
SECTOR Toy industry
TAMAÑO 770*770*700 mm
PESO 2,7 Tons
CAVIDADES 1
MATERIAL Steel 2738 HRC34-38 (cavity and core).
 S50C (ejector plate and spare parts).
INYECCIÓN Cold runner, direct gate
EYECCIÓN Ejector sleeve
CICLO 60 seconds
MOLD RUNNER 500.000 shots



PRODUCTO: Plastic Child Sand Scoop (PP)

NOMBRE Sand Scoop Injection Mould
SECTOR Toy industry
TAMAÑO 675*40*400 mm
PESO 100 Tons
CAVIDADES 2+2
MATERIAL P20 steel (main)
INYECCIÓN Cold runner

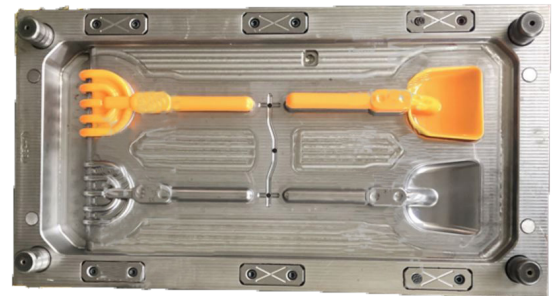

PRODUCTO: Plastic gun toy part (PP)

NOMBRE Kids gun toy mold
SECTOR Toy industry
CAVIDADES 2
MATERIAL 1.2344 steel
INYECCIÓN Hot runner
MOLD RUNNER 500.000 shots
CARACTERÍSTICAS Polishing MT11010

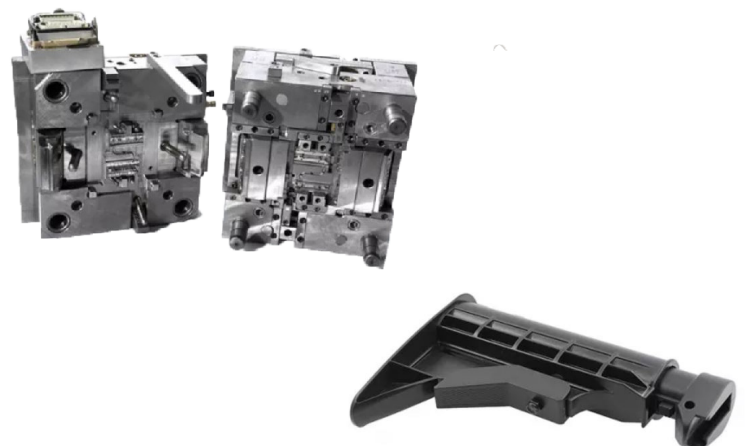

Moldes de inyección

ELECTRODOMÉSTICOS

PRODUCTO: Top load washing machine (700*400*186 mm)

NOMBRE	Washing machine mold
SECTOR	Household
TAMAÑO	1150*850*680 mm
PESO	550 Tons
CAVIDADES	1
MATERIAL	718H
INYECCIÓN	4 tips hot runner
EYECCIÓN	Ejector pins
CICLO	72 seconds
MOLD RUNNER	500.000 shots
CARACTERÍSTICAS	To choose the adequate steel to guarantee perfect parting line and last shining.

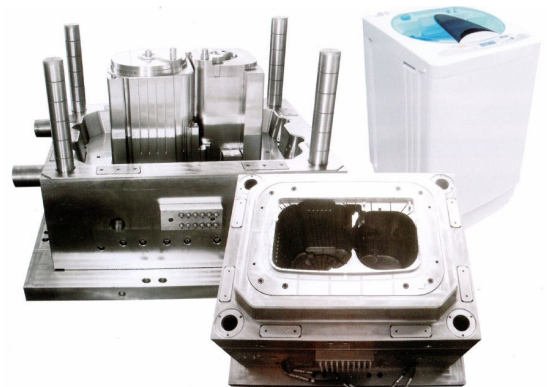

PRODUCTO: SIEMENS air conditioner (750*200*200 mm)

NOMBRE	Air conditioner mold
SECTOR	Household
TAMAÑO	1100*750*850 mm
PESO	850 Tons
CAVIDADES	1
MATERIAL	DIN 1.2738
INYECCIÓN	Pin-point gate, 2 points.
EYECCIÓN	Ejector pin and ejector block
CICLO	50 seconds
MOLD RUNNER	800.000 shots
CARACTERÍSTICAS	High polishing required



Moldes de inyección

ELECTRODOMÉSTICOS

PRODUCTO: Computer mouse housing (ABS)

NOMBRE Computer mouse mold

SECTOR Computer

TAMAÑO 280*380*250 mm

CAVIDADES 4

MATERIAL 718 (cavity & core)

CICLO 30 seconds

MOLD RUNNER 500.000 shots

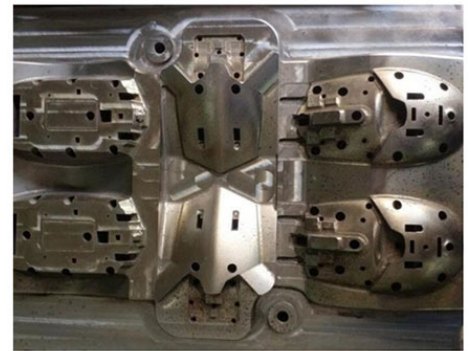

PRODUCTO: Fan blade (300*300*180 mm, ABS)

NOMBRE Fan blade mold

SECTOR Household / Industrial

TAMAÑO 800*800*680 mm

PESO 650 Tons

CAVIDADES 1

MATERIAL S136

INYECCIÓN Hot runner

EYECCIÓN Ejector plate

CICLO 20 seconds

MOLD RUNNER 1 million

CARACTERÍSTICAS Multi-slider movements.
Balance test, high precision.

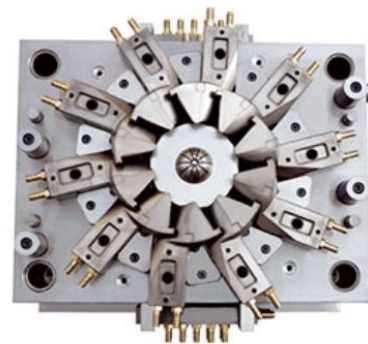

Moldes de inyección ENVASES Y TAPONES

PRODUCTO: Bottle cap (PCO 28 mm)

NOMBRE 72-Cavity bottle cap injection mold
SECTOR Water industry
TAMAÑO 1320*620*759 mm
PESO 600 Tons
CAVIDADES 72
MATERIAL S136 stainless steel with HRC48-50
INYECCIÓN Hot runner gate
EYECCIÓN Stripper
CICLO 7 seconds
MOLD RUNNER 5 million
CARACTERÍSTICAS Productivity 26.000-30.000 pcs/hour.
Full hot runner system with German heater.
Interchangeable core and cavity.



PRODUCTO: PET Preform (PCO 28 mm)

NOMBRE PET preform mold
SECTOR Food industry
CAVIDADES 32
MATERIAL StavaxS420 HRC55 (cavity & core).
DIN 1.2311 with precision grinding (base).
Spare parts in DIN 1.2344 in DME metric dimension
standard.
Screw neck slide piece inserted with pre-hardened
DIN 1.2316 HRC42.
INYECCIÓN Valve gate with interchangeable melt PET material
sealing.
CARACTERÍSTICAS Precision temperature controlling for multi-cavity.

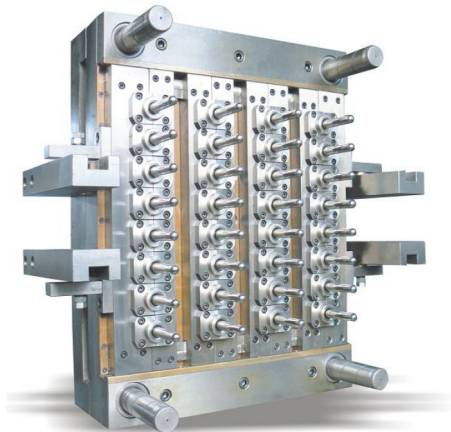

Moldes de inyección ENVASES Y TAPONES

PRODUCTO: Food container (PP, 540 ml)

NOMBRE Container mold
SECTOR Food industry
PESO 250 Tons
CAVIDADES 4
INYECCIÓN Hot runner, valve gate inside
EYECCIÓN Free drop
CICLO Below 5 seconds
MOLD RUNNER 3 million
CARACTERÍSTICAS Square core locking



PRODUCTO: Spoon (PLA)

NOMBRE PLA spoon mold
SECTOR Food industry
MATERIAL S420 stainless steel with HRC44-48
INYECCIÓN 2 tips hot runner
CICLO 8 seconds
MOLD RUNNER 5 million
CARACTERÍSTICAS Designed as per PP, PS or PLA

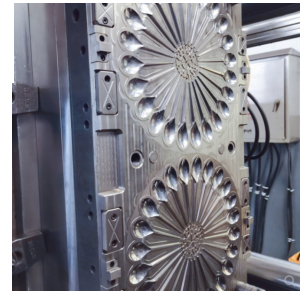
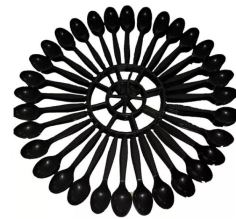

PRODUCTO: Flip top cap (PP)

NOMBRE Cap mold
SECTOR Food industry
PESO 160 Tons
CAVIDADES 1.2344ESR steel
INYECCIÓN Mold master hot runner, HASCO components
CICLO 15 seconds
CARACTERÍSTICAS In mold closing mechanism.
 Intensive cooling system.



Moldes de inyección

IML

PRODUCTO: IML painting bucket (20 L)

NOMBRE Plastic bucket mold

TAMAÑO 700*700*750 mm

PESO 600 Tons

CAVIDADES 1

MATERIAL DIN 1.2344 + Copper Beryllium

INYECCIÓN 1 point valve gate

EYECCIÓN Inclined ejecting stripper, full automaticity

CICLO 18 seconds

MOLD RUNNER 5 million

CARACTERÍSTICAS Copper Beryllium (moldmax) on the top core and cavity edge, leads to best cooling effect for high speed injection.

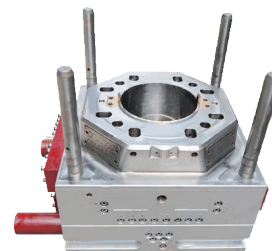
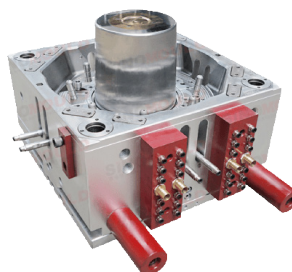

PRODUCTO: Cookies bucket (2L, 0,85 mm thickness)

NOMBRE IML 2L bucket mold

SECTOR Food industry

MATERIAL S420 stainless steel with HRC44-48

INYECCIÓN Hot runner, Yudo 2 tips valve gate

CICLO 10 seconds IML included

MOLD RUNNER 3 million shorts

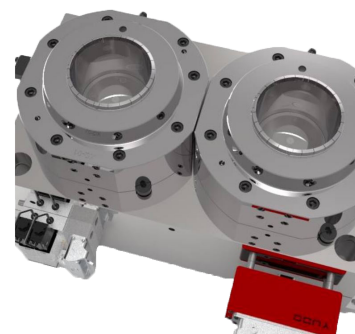

Moldes de inyección

ACCESORIOS TUBERÍAS

PRODUCTO: Elbow (PVC, DN 40 90°)

NOMBRE Elbow mold

SECTOR Pipe fittings

CAVIDADES 16

CICLO 48 seconds

CARACTERÍSTICAS High productivity

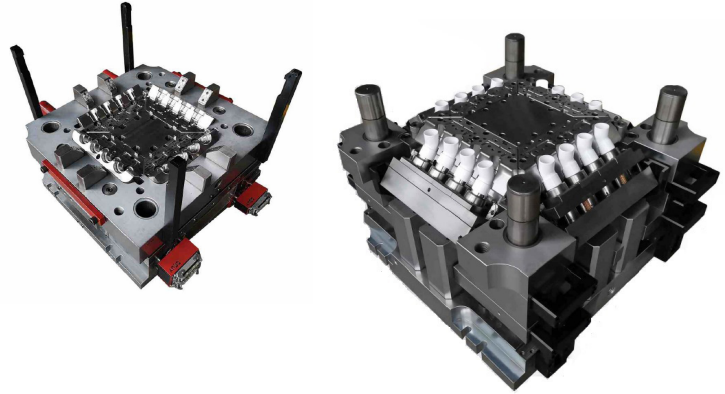

PRODUCTO: Manhole (PE, D630)

NOMBRE Big size manhole mold

PESO 2500 Tons

CARACTERÍSTICAS 4 articles Interchangeable
All trial adjustment is completed
at our facilities

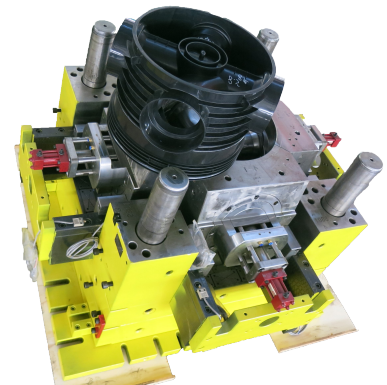

PRODUCTO: Elbow (DN 50, 90°)

NOMBRE Stack mold

SECTOR Pipe fittings

CARACTERÍSTICAS 2 x 4 cavity mold

