

Injection molds

AUTOMOTIVE

PRODUCT: PEUGEOT 408 front bumper (PP) - 1757*643*646 mm

MOLD NAME Front bumper mold
SECTOR Automotive
MOLD SIZE 2632*1530*1781mm
CAVITY NUMBER 1
MATERIAL German 1.2311 (Cavity&Core)
EJECTION SYSTEM Cylinder
INJECTION Hot runner 9-point valve pin

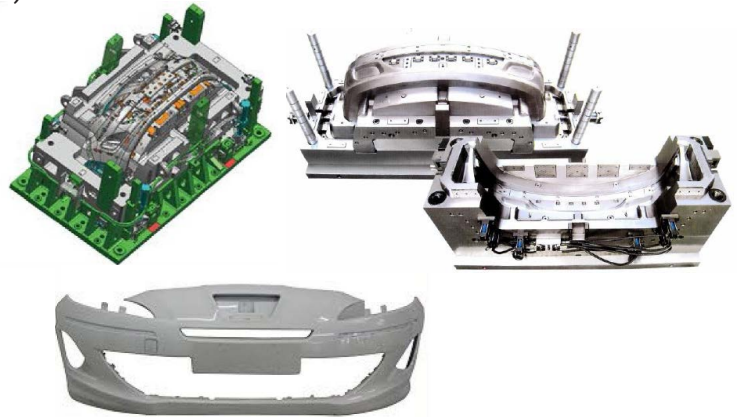

PRODUCT: MITSUBISHI MOTOR door panel (PPT10) - 950*450*75 mm

MOLD NAME Door car panel mold
SECTOR Automotive / Column serie
MOLD SIZE 1200x1350x838 mm
MOLD WEIGHT 7,9 Tons
CAVITY NUMBER 1
MATERIAL Cavity 718H ; Core: P20
EJECTION SYSTEM Hydraulic cylinder
INJECTION Hot runner 4-point valve pin



PRODUCT: HONDA radiator holder (PP 40%LGF) - 1483*603*472 mm

MOLD NAME Radiator holder mold
SECTOR Automotive
MOLD SIZE 2090*1600*1366 mm
MOLD WEIGHT 22 Tons
CAVITY NUMBER 1*1
MATERIAL Cavity 1.2711 ; Core: 1.2711
EJECTION SYSTEM Hydraulic ejection
INJECTION Hot runner 5-point valve pin

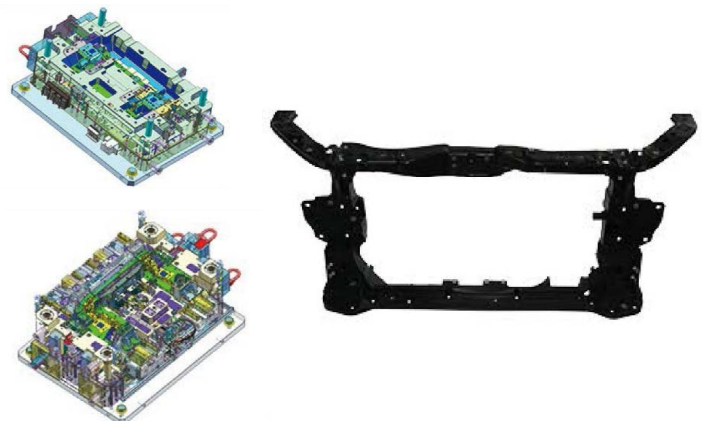

Injection molds

AUTOMOTIVE

PRODUCT: NISSAN front radiator grill (PP) - 950*350*170 mm

MOLD NAME Front radiator grill mold
SECTOR Automotive
MOLD SIZE 1450*1050*1030 mm
MOLD WEIGHT 8,6 Tons
CAVITY NUMBER 1*1
MATERIAL Cavity 1.2738; Core P20
EJECTION SYSTEM Hydraulic cylinder
INJECTION Hot runner 5 point valve pin

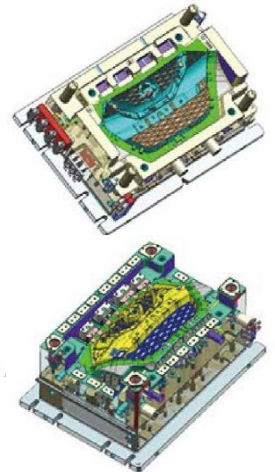

PRODUCT: PEUGEOT instrument panel (PP) - 1398*588*458 mm

MOLD NAME Instrument panel mold
SECTOR Fascia / Instrument panel
MOLD SIZE 2700*1620*1600 mm
MOLD WEIGHT 31 Tons
CAVITY NUMBER 1
MATERIAL Cavity 1.2738; Core P20
EJECTION SYSTEM Hydraulic cylinder
INJECTION Hot runner 6 point valve pin

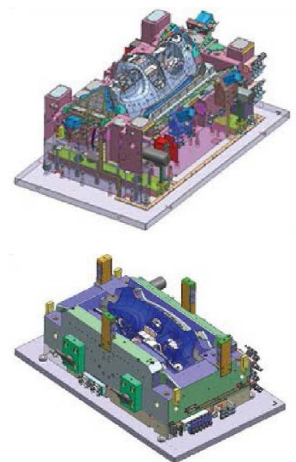

Injection molds

CONTAINERS AND CAPS

PRODUCT: Bottle cap (PCO 28 mm)

NAME/USAGE	72-Cavity bottle cap injection mold
SECTOR	Water industry
MOLD SIZE	1320*620*759 mm
SUITABLE MACHINE	600 Tons
CAVITY NUMBER	72
MATERIAL	S136 stainless steel with HRC48-50
INJECTION	Hot runner gate
EJECTION SYSTEM	Stripper
CYCLE	7 seconds
MOLD RUNNER	5 million
KEY FEATURE	Productivity 26.000-30.000 pcs/hour. Full hot runner system with German heater. Interchangeable core and cavity.



PRODUCT: PET Preform (PCO 28 mm)

NAME/USAGE	PET preform mold
SECTOR	Food industry
CAVITY NUMBER	32
MATERIAL	StavaxS420 HRC55 (cavity & core). DIN 1.2311 with precision grinding (base). Spare parts in DIN 1.2344 in DME metric dimension standard. Screw neck slide piece inserted with pre-hardened DIN 1.2316 HRC42.
INJECTION	Valve gate with interchangeable melt PET material sealing.
KEY FEATURE	Precision temperature controlling for multi-cavity.

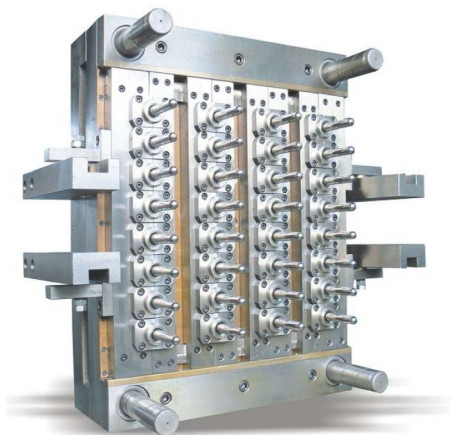

Injection molds

CONTAINERS AND CAPS

PRODUCT: Food container (PP, 540 ml)

NAME/USAGE Container mold
SECTOR Food industry
SUITABLE MACHINE 250 Tons
CAVITY NUMBER 4
INJECTION Hot runner, valve gate inside
EJECTION SYSTEM Free drop
CYCLE Below 5 seconds
MOLD RUNNER 3 million
KEY FEATURE Square core locking



PRODUCT: Spoon (PLA)

NAME/USAGE PLA spoon mold
SECTOR Food industry
MATERIAL S420 stainless steel with HRC44-48
INJECTION 2 tips hot runner
CYCLE 8 seconds
MOLD RUNNER 5 million
KEY FEATURE Designed as per PP, PS or PLA

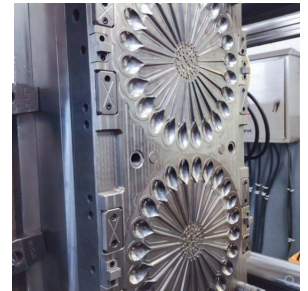
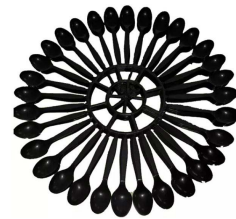

PRODUCT: Flip top cap (PP)

NAME/USAGE Cap mold
SECTOR Food industry
SUITABLE MACHINE 160 Tons
CAVITY NUMBER 1.2344ESR steel
INJECTION Mold master hot runner, HASCO components
CYCLE 15 seconds
KEY FEATURE In mold closing mechanism.
 Intensive cooling system.

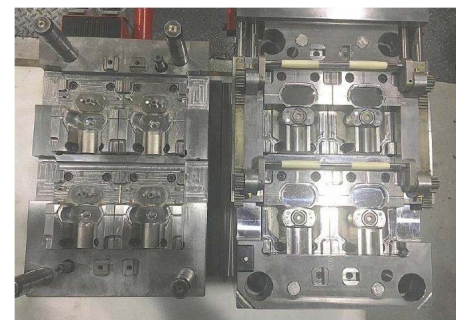

Injection molds

CRATES AND PALLETS

PRODUCT: Fruit crate (400*300*160 mm)

NAME/USAGE Plastic crate mold
SECTOR Food industry
MOLD SIZE 1520*1202*850 mm
SUITABLE MACHINE 1200 Tons
CAVITY NUMBER 4
MATERIAL MoldMAX Copper Beryllium + DIN 1.2311
INJECTION 16 points hot nozzle with point gate
EJECTION SYSTEM Stripper plate
CYCLE 25 seconds
MOLD RUNNER 5 million, full automatic.
KEY FEATURE The application of Copper Beryllium leads to best cooling effect.
Hot runner professional filter system design, suitable for high speed recycled material injection production.

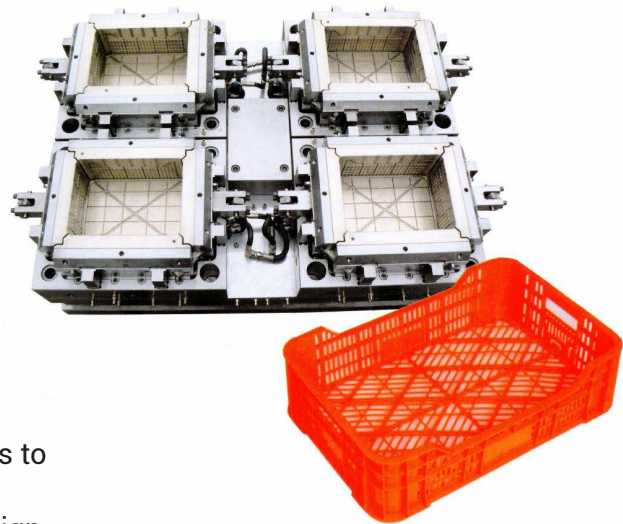

PRODUCT: Large box (1200*1000*760 mm)

NAME/USAGE Large size box mold
SECTOR Packaging
MOLD SIZE 2250*2450*1800 mm
SUITABLE MACHINE 3350 Tons
CAVITY NUMBER 1
MATERIAL P20HH
INJECTION Hot runner 21 tips
EJECTION SYSTEM Ejector block
CYCLE 180 seconds
MOLD RUNNER 500.000 shots
KEY FEATURE Fully automatic production line.
Large mold and very special complex molding structure part



Injection molds

CRATES AND PALLETS

PRODUCT: Dual-layer pallet (1400*1200*150 mm)

NAME/USAGE	Pallet mold
SECTOR	Packaging
MOLD SIZE	1800*1800*1100 mm
SUITABLE MACHINE	2250 Tons
CAVITY NUMBER	1
MATERIAL	DIN 1.2311
INJECTION	16 pints hot runner gate
EJECTION SYSTEM	Ejector pin and ejecting block
CYCLE	95 seconds
MOLD RUNNER	1 million
KEY FEATURE	Suitable for high speed recycled material injection production.

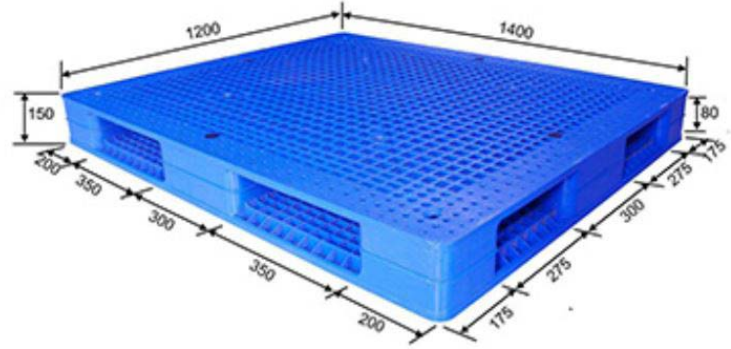

Injection molds

FURNITURE

PRODUCT: Rattan plastic chair (580*600*900 mm)

NAME/USAGE Gas-assisted chair mold
SECTOR Furniture
MOLD SIZE 1818*1400*1227 mm
SUITABLE MACHINE 1650 Tons
CAVITY NUMBER 1
MATERIAL DIN 1.2738
INJECTION Cold runner
EJECTION SYSTEM Ejection pin
CYCLE 5 minutes
MOLD RUNNER 1 million
KEY POINTS Gas assisted mold



PRODUCT: Beach chair

NAME/USAGE Beach chair mold
SECTOR Furniture
MOLD SIZE 2800*1450*1320 mm
SUITABLE MACHINE 550 Tons
CAVITY NUMBER 1
MATERIAL 718H
INJECTION Hot runner 12 tips
EJECTION SYSTEM Ejector pin
CYCLE 72 seconds
MOLD RUNNER 500.000 shots
KEY POINTS High effect of cooling in mould
 Automatic drop in running
 Good finish of the chair surface



Injection molds

FURNITURE

PRODUCT: Plastic arm chair (1200*750*700 mm)

NAME/USAGE Arm Chair Mould
SECTOR Furniture
MOLD SIZE 1350*860*800mm
SUITABLE MACHINE 850 Tons
CAVITY NUMBER 1
MATERIAL P20
INJECTION 1-point hot runner direct cone gate
EJECTION SYSTEM Ejector pin
CYCLE 45 seconds
MOLD RUNNER 800.000 shots
KEY POINTS Special design cone gate



PRODUCT: Plastic chair, rattan surface finish (550*550*850 mm)

NAME/USAGE Gas-assisted chair mold
SECTOR Furniture
MOLD SIZE 1400*900*850 mm
SUITABLE MACHINE 1150 Tons
CAVITY NUMBER 1
MATERIAL 2738H steel
INJECTION YUDO hot runner
EJECTION SYSTEM Ejection pin
CYCLE 55 sec.
MOLD RUNNER 1 million
KEY POINTS Gas injection mold, transmit pressure uniformly on such smaller machines (Reduce of power consumption), moulded in strees.
High precision texture (improved dimensional stability with no distorsion)
Thick sections



Injection molds

HEALTHCARE AND MEDICAL

PRODUCT: Petri dish

NAME/USAGE Petri dish mold
SECTOR Medical
SUITABLE MACHINE 200 Tons
CAVITY NUMBER 2+2 family mold
MATERIAL S136
CYCLE 8 seconds
MOLD RUNNER 5 million strokes



PRODUCT: COVID-19 ANTIGEN SELF TEST (PP)

NAME/USAGE Self test device mold
SECTOR Medical
CAVITY NUMBER 64 cavities
MATERIAL S136 (main)
INJECTION Yudo point gate
CYCLE 10 seconds

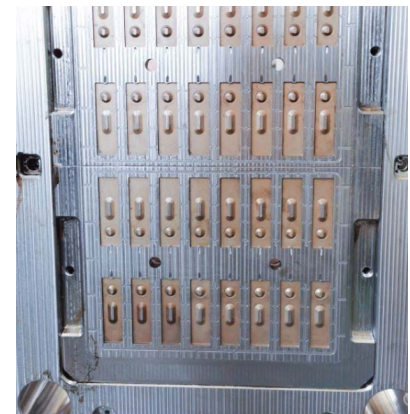

Injection molds

HEALTHCARE AND MEDICAL

PRODUCT: Blood collection tube (PET, Ø 12,5*75 mm)

NAME/USAGE Test tube mold
SECTOR Medical
MOLD SIZE 660*500*478 mm
SUITABLE MACHINE 200 Tons
CAVITY NUMBER 32 cavities
MATERIAL S136 (Cavity & core)
INJECTION 32 tip valve gate
EJECTION SYSTEM Stripper plate
CYCLE 12 seconds
MOLD RUNNER 5 million shots
KEY FEATURE High speed mold.
High transmittance surface without sink mark.
High precision tooling control without eccentricity.



PRODUCT: Disposable syringe (PP)

NAME/USAGE Syringe mold
SECTOR Medical
CAVITY NUMBER 64 cavities
MATERIAL Stavax S136 steel
INJECTION Point gate
MOLD RUNNER 5 million shots
KEY FEATURE Interchangeable inserts

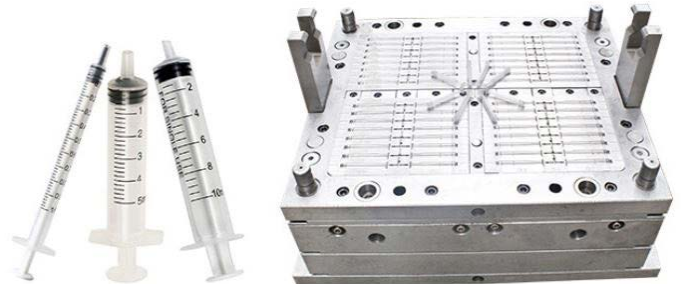

Injection molds

HOUSEHOLD ELECTRICAL APPLIANCE

PRODUCT: Top load washing machine (700*400*186 mm)

NAME/USAGE	Washing machine mold
SECTOR	Household
MOLD SIZE	1150*850*680 mm
SUITABLE MACHINE	550 Tons
CAVITY NUMBER	1
MATERIAL	718H
INJECTION	4 tips hot runner
EJECTION SYSTEM	Ejector pins
CYCLE	72 seconds
MOLD RUNNER	500.000 shots
KEY FEATURE	To choose the adequate steel to guarantee perfect parting line and last shining.

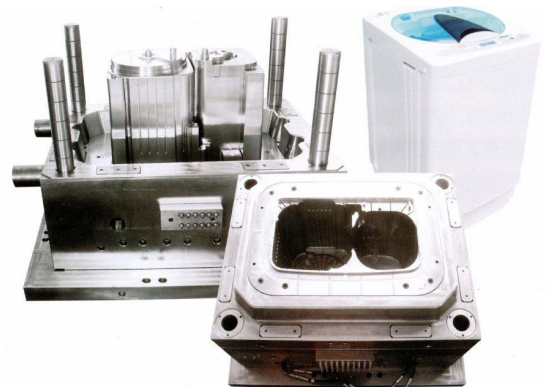

PRODUCT: SIEMENS air conditioner (750*200*200 mm)

NAME/USAGE	Air conditioner mold
SECTOR	Household
MOLD SIZE	1100*750*850 mm
SUITABLE MACHINE	850 Tons
CAVITY NUMBER	1
MATERIAL	DIN 1.2738
INJECTION	Pin-point gate, 2 points.
EJECTION SYSTEM	Ejector pin and ejector block
CYCLE	50 seconds
MOLD RUNNER	800.000 shots
KEY FEATURE	High polishing required



Injection molds

HOUSEHOLD ELECTRICAL APPLIANCE

PRODUCT: Computer mouse housing (ABS)

NAME/USAGE Computer mouse mold
SECTOR Computer
MOLD SIZE 280*380*250 mm
CAVITY NUMBER 4
MATERIAL 718 (cavity & core)
CYCLE 30 seconds
MOLD RUNNER 500.000 shots



PRODUCT: Fan blade (300*300*180 mm, ABS)

NAME/USAGE Fan blade mold
SECTOR Household / Industrial
MOLD SIZE 800*800*680 mm
SUITABLE MACHINE 650 Tons
CAVITY NUMBER 1
MATERIAL S136
INJECTION Hot runner
EJECTION SYSTEM Ejector plate
CYCLE 20 seconds
MOLD RUNNER 1 million
KEY FEATURE Multi-slider movements.
 Balance test, high precision.

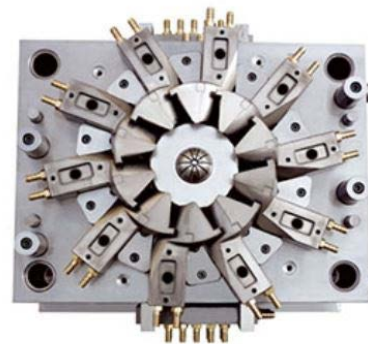

Injection molds

IN-MOLD LABELLING (IML)

PRODUCT: IML painting bucket (20 L)

NAME/USAGE Plastic bucket mold
MOLD SIZE 700*700*750 mm
SUITABLE MACHINE 600 Tons
CAVITY NUMBER 1
MATERIAL DIN 1.2344 + Copper Beryllium
INJECTION 1 point valve gate
EJECTION SYSTEM Inclined ejecting stripper, full automaticity
CYCLE 18 seconds
MOLD RUNNER 5 million
KEY FEATURE Copper Beryllium (moldmax) on the top core and cavity edge, leads to best cooling effect for high speed injection.

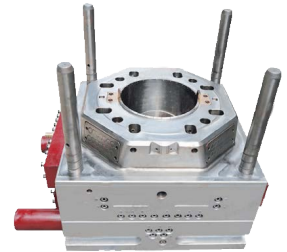
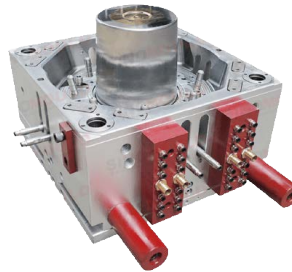

PRODUCT: Cookies bucket (2L, 0,85 mm thickness)

NAME/USAGE IML 2L bucket mold
SECTOR Food industry
MATERIAL S420 stainless steel with HRC44-48
INJECTION Hot runner, Yudo 2 tips valve gate
CYCLE 10 seconds IML included
MOLD RUNNER 3 million shorts

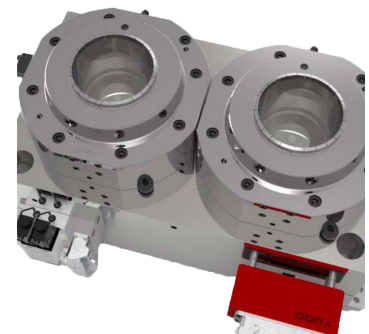

Injection molds

INDUSTRIAL

PRODUCT: Motor POM gear (35,5*35,5*21,5 mm)

NAME/USAGE High precision gear mold
MOLD SIZE 388*361*450 mm
MATERIAL Steel 8407
INJECTION 3-plate point gate
EJECTION SYSTEM Ejector pin
CYCLE 22 seconds
MOLD RUNNER 500.000 shots
KEY FEATURE Control of the POM shrinkage and product thickness.
 POM product has high rigidity and sound abrasion resistance.



PRODUCT: White cover, ASA material (124*152*80 mm)

NAME/USAGE Plastic cover mold
MOLD SIZE 600*610*880 mm
MOLD WEIGHT 875 Kg
CAVITY NUMBER 2
MATERIAL Steel 2343ESR
MOLD RUNNER Cold runner to sub gate
KEY FEATURE Hot sprue bushing.
 Slider core side.
 2343ESR offers good toughness, excellent heat resistance and resistance to wear and thermal shock.

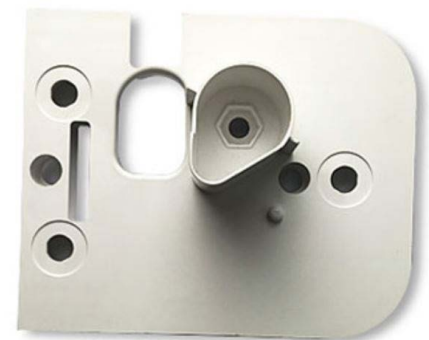

Injection molds

INDUSTRIAL

PRODUCT: Lawn mower cover (450*700*350 mm)

NAME/USAGE	Plastic lawn mower mold
SECTOR	Gardening
MOLD SIZE	1200*850*700 mm
SUITABLE MACHINE	850 Tons
CAVITY NUMBER	1
MATERIAL	2378
INJECTION	Hot runner
EJECTION SYSTEM	Ejector pin
CYCLE	40 seconds
MOLD RUNNER	1 million



Injection molds

PIPE FITTINGS

PRODUCT: Elbow (PVC, DN 40 90°)

NAME/USAGE Elbow mold
SECTOR Pipe fittings
CAVITY NUMBER 16
CYCLE 48 seconds
KEY FEATURE High productivity



PRODUCT: Manhole (PE, D630)

NAME/USAGE Big size manhole mold
SUITABLE MACHINE 2500 Tons
KEY FEATURE 4 articles Interchangeable
All trial adjustment is completed at our facilities

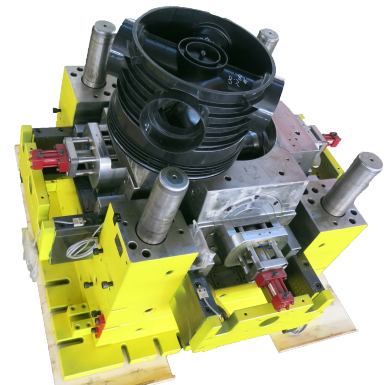

PRODUCT: Elbow (DN 50, 90°)

NAME/USAGE Stack mold
SECTOR Pipe fittings
KEY FEATURE 2 x 4 cavity mold

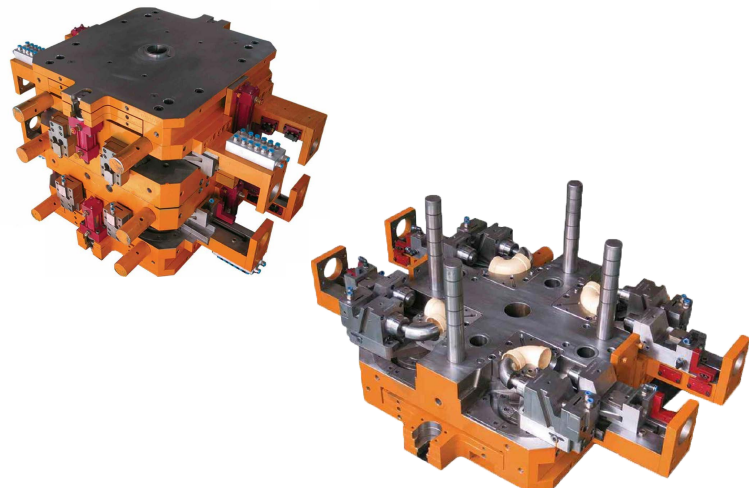

Injection molds

AGRICULTURE

PRODUCT: Knapsack Sprayer Tank Body (PP/ABS)

MOLD NAME knapsack Tank Injection mold
SECTOR Agriculture
CAVITY NUMBER 1
MATERIAL P20 prehardened steel
 S136 (cavity & core)
INJECTION Cold runner
MOLD RUNNER 500.000 shots



PRODUCT: Drip pipe connector (PP)

NAME/USAGE Agriculture drip pipe mold
SECTOR Piping sector
MOLD SIZE 490*840*465 mm
SUITABLE MACHINE 150 Tons
CAVITY NUMBER 16
MATERIAL Stavax S136 HRC45-48 (Core & cavity)
INJECTION 4 tip hot runner point gate

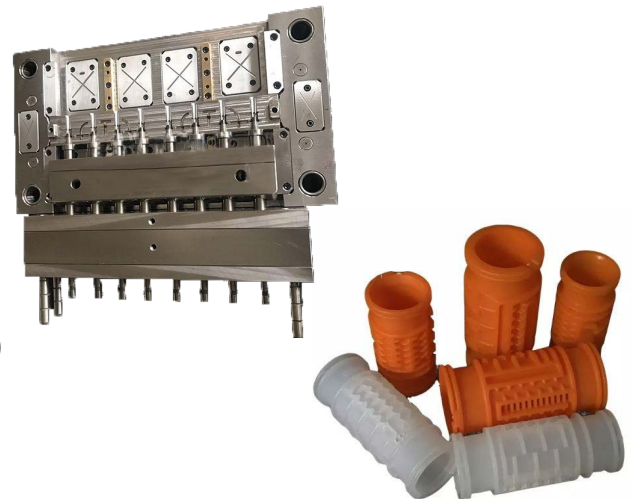

PRODUCT: Plastic cap (PE)

NAME/USAGE Bottle cap mold
SECTOR Agriculture
CAVITY NUMBER 4
MATERIAL P20 prehardened steel
 S136 HRC46-50 (cavity & core)
INJECTION Hot runner
MOLD RUNNER 1 million



Injection molds

TOYS

PRODUCT: Plastic car (PP, 528*500*270 mm)

NAME/USAGE Toy car mold
SECTOR Toy industry
MOLD SIZE 770*770*700 mm
MOLD WEIGHT 2,7 Tons
SUITABLE MACHINE 800 Tons
CAVITY NUMBER 1
MATERIAL Steel 2738 HRC34-38 (cavity and core).
 S50C (ejector plate and spare parts).
INJECTION Cold runner, direct gate
EJECTION SYSTEM Ejector sleeve
CYCLE 60 seconds
MOLD RUNNER 500.000 shots



PRODUCT: Plastic Child Sand Scoop (PP)

NAME/USAGE Sand Scoop Injection Mould
SECTOR Toy industry
MOLD SIZE 675*40*400 mm
SUITABLE MACHINE 100 Tons
CAVITY NUMBER 2+2
MATERIAL P20 steel (main)
INJECTION Cold runner

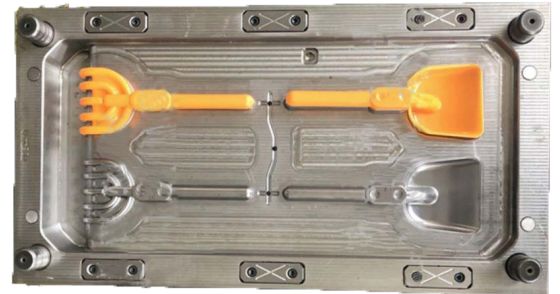

PRODUCT: Plastic gun toy part (PP)

NAME/USAGE Kids gun toy mold
SECTOR Toy industry
CAVITY NUMBER 2
MATERIAL 1.2344 steel
INJECTION Hot runner
MOLD RUNNER 500.000 shots
KEY FEATURE Polishing MT11010

