

## VÁLVULAS

Gestión de Compras suministra todo tipo de válvulas, según normativas ANSI, ASA, BS, DIN, ISO, China GB/T, etc., así como según especificaciones del cliente.

Suministramos válvulas de mariposa, válvulas tipo WAFER, válvulas de bola, válvulas de compuerta, válvulas globo, válvulas de retención, válvulas de control, válvulas antirretorno (hidráulica), válvulas de diafragma, etc.

En cuanto a los materiales, los más utilizados son el acero al carbono, acero inoxidable, bronce, fundición, etc.





## Butterfly Valves

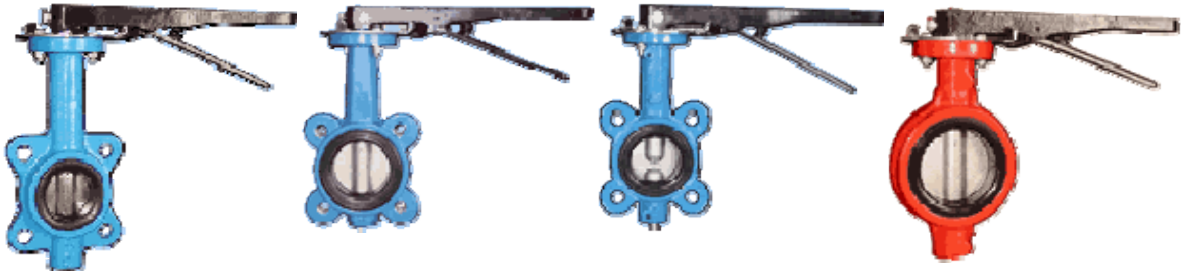

Butterfly Valve BV1000 Butterfly Valve BV2000 Butterfly Valve BV3000 Butterfly Valve BV4000

### Butterfly Valve BV1000W Dimensions and Weight

BV1000W is Wafer Butterfly valve. It can be manufactured as with pin butterfly valves or without pin butterfly valves. The size is for 2"(DN50) to 40" (DN1000). It is with back-up seat and double D type disc. The connection between the discs and stems is of three types, square connected, key connected, spline connected. Valve body features four alignment holes. Valve with handles (2" to 12"), Manual Gear Operators (2" to 40") and electric or pneumatic actuators (2" to 40"). Face to face dimensions are available in GB 12238 BS5155 API609, MSS SP-76, DIN 3202-K1 (ISO 5762 T5). Flange drilling according to: GB9112-88, DIN2501, BS4504, ISO2084, ISO2531, BS10-E, ANSI125/150, ASA125/150, AS2129 Table D/E. Valve tested: API598 Safe working pressure: PN6,10,16.

Fig: Butterfly Wafer Valve BV1000W

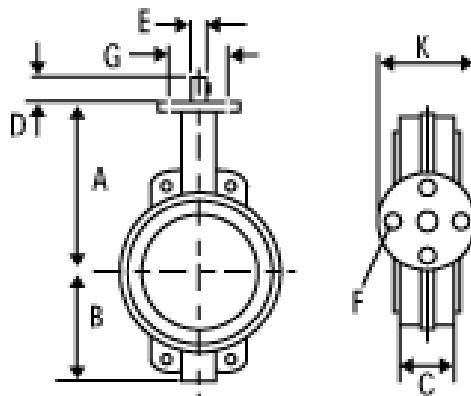

Size	A	B	C	D	E	F	G	K
50	161	80	43	32	12.6	6.7	50	65
65	175	89	46	32	12.6	6.7	50	65
80	181	95	46	32	12.6	6.7	50	65
100	200	114	52	32	15.77	10.3	70	90
125	213	127	56	32	18.92	10.3	70	90
150	226	139	56	32	18.92	10.3	70	90
200	260	175	60	40	22.10	14.3	102	125
250	292	203	68	40	28.45	14.3	102	125
300	337	242	78	40	31.6	14.3	102	125
350	368	267	78	40	31.6	14.3	125	150
400	400	298	102	51.2	33.15	20.6	140	175
450	422	318	114	51.2	38.00	20.6	140	175

500	480	249	127	64.2	41.15	20.6	140	175
600	562	440	154	70.2	50.65	23.2	165	210
700	624	520	163	66	55.00	8-18	254	300
800	672	591	188	66	55.00	8-18	254	300

**NOTE:**

Dimensions of "M", "L1", "L2", "D1" for the following Standard available: GB9112-88, DIN2501, BS4504, ISO2084, ISO2531, BS10-E, ANSI15/150, ASA125/150.AS2129 Table

**Weight List (kg)**

Size	Wafer	Size	Wafer
50(2")	2.5	300(12")	32.5
65(2.5")	3.2	350(14")	41.3
80(3")	3.6	400(16")	61
100(4")	4.9	450(18")	87
125(5")	7	500(20")	98
150(6")	7.8	600(24")	133
200(8")	13.2	700(28")	187
250(10")	19.2	800(32")	387

**Butterfly valve BV1000L Dimensions and Weight**

BV1000L is Lug Type Butterfly Valve. It can be manufactured as with pin butterfly valves or without pin butterfly valves. The size is for 2"(DN50) to 40" (DN1000). It is with back-up seat and double D type disc. The connection between the discs and stems is of three types, square connected, key connected, spline connected. Valve body features four alignment holes at least. Valve can be mounted with handles (2" to 12"), Manual Gear Operators (2" to 40",) and electric or pneumatic actuators (2" to 40"). Face to face dimensions are available in GB 12238 BS5155 API609, MSS SP-76, DIN 3202-K1 (ISO 5762 T5).

Flange Drilling according to: GB9112-88, DIN2501, BS4504, ISO2084, ISO2531, BS10-E, ANSI125/150, ASA125/150, AS2129 Table D/E. Valve tested: API598 Safe working pressure: PN6,10,16.

**Fig: Butterfly Lug Valve BV1000L**

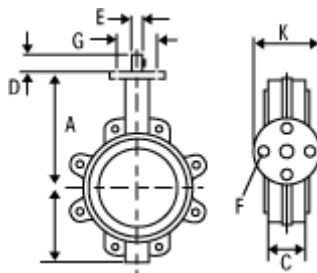

Size	A	B	C	D	E	F	G	K
50	161	80	43	32	12.6	6.7	50	65
65	175	89	46	32	12.6	6.7	50	65
80	181	95	46	32	12.6	6.7	50	65
100	200	114	52	32	15.77	10.3	70	90
125	213	127	56	32	18.92	10.3	70	90
150	226	139	56	32	18.92	10.3	70	90
200	260	175	60	40	22.10	14.3	102	125
250	292	203	68	40	28.45	14.3	102	125

300	337	242	78	40	31.6	14.3	102	125
350	368	267	78	40	31.6	14.3	125	150
400	400	298	102	51.2	33.15	20.6	140	175
450	422	318	114	51.2	38.00	20.6	140	175
500	480	249	127	64.2	41.15	20.6	140	175
600	562	440	154	70.2	50.65	23.2	165	210
700	624	520	163	66	55.00	8-18	254	300
800	672	591	188	66	55.00	8-18	254	300

**NOTE:**

Dimensions of "M", "L1", "L2", "D1" for the following Standard available: GB9112-88, DIN2501, BS4504, ISO2084, ISO2531, BS10-E, ANSI15/150, ASA125/150. AS2129 Table

**Weight List (kg)**

Size	Lug	Size	Lug
50(2")	3.8	300(12")	40
65(2.5")	4.2	350(14")	56
80(3")	4.7	400(16")	90
100(4")	9.0	450(18")	111
125(5")	10.9	500(20")	123
150(6")	14.2	600(24")	178
200(8")	18.2	700(28")	ii
250(10")	26.8	800(32")	ii

## Butterfly Valve BV1000S Dimensions and Weight

BV1000S is Wafer Butterfly valve. The size is for 2"(DN50) to 40" ( DN1000). It is with back-up seat and double D type disc. Valve body features six alignment holes. Valve with handles (2" to 12"), Manual Gear Operators (2" to 40"), and electric or pneumatic actuators (2" to 40")

Face to face dimension are available in GB 12238 BS5155 API609, MSS SP-76, DIN 3202-K1 (ISO 5762 T5).

Flange drilling are universal standard, suitable for DIN PN10/PN16 ANSI 125/150 JIS 10k as well.

Valve design : ISO 7005-2

Valve tested: API598

Safe working pressure: PN6,10,16.

### Fig: Butterfly Wafer Valve BV1000S

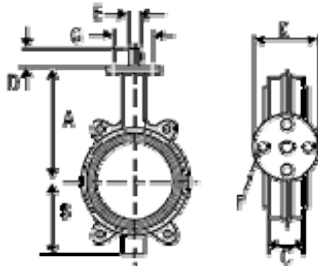

Size	A	B	C	D	E	F	G	K
40	120	67	33	32	12.6	7	50	65
50	140	80	43	32	12.6	7	50	65
65	155	89	46	32	12.6	7	50	65
80	160	95	46	32	12.6	7	50	65
100	180	114	52	32	15.77	9	70	90

125	193	127	56	32	18.92	9	70	90
150	200	139	56	32	18.92	9	70	90
200	240	175	60	40	22.10	11	102	125
250	272	203	68	40	28.45	11	102	125
300	317	242	78	40	31.6	11	102	125
350	368	267	78	40	31.6	13	125	150
400	400	298	102	51.2	33.15	17	140	175
450	422	318	114	51.2	38.00	17	140	175
500	480	249	127	64.2	41.15	17	140	175
600	562	440	154	70.2	50.65	21	165	210
700	624	520	163	66	55.00	8*17	254	300
800	672	591	188	66	55.00	8*17	254	300

Dimensions of "M", "L1", "L2", "D1" for the following Standard available: GB9112-88, DIN2501, BS4504, ISO2084, ISO2531, BS10-E, ANSI15/150, ASA125/150. AS2129 Table

### Weight List (kg)

Size	Wafer	Size	Wafer
50(2")	2.5	300(12")	32.5
65(2.5")	3.2	350(14")	41.3
80(3")	3.6	400(16")	61
100(4")	4.9	450(18")	87
125(5")	7	500(20")	98
150(6")	7.8	600(24")	133
200(8")	13.2	700(28")	187
250(10")	19.2	800(32")	387

### Butterfly Valve BV2000W

BV2000W is Wafer Butterfly valve with pin. The size is for 2"(DN50) to 14" ( DN350). It is with soft seat and double D type disc. Valve body features four alignment holes at least. Valve can be mounted with handles (2" to 12"), Manual Gear Operators (2" to 14"), and electric or pneumatic actuators (2" to 14")

Face to face dimension are available in GB 12238 BS5155 API609, MSS SP-76, DIN 3202-K1 (ISO 5762 T5).

Flange drilling are universal standard, suitable for DIN PN10/PN16 ANSI 125/150 JIS 10k as well.

Valve tested: API598

Safe working pressure: PN6,10,16.

**Fig: Butterfly Wafer Valve BV2000W**

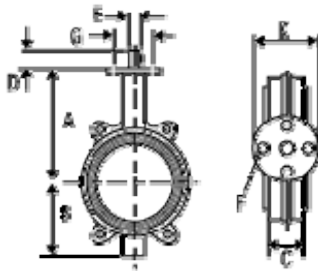

Dimensions and Weight

Size	A	B	C	D	E	F	G	K
50	143	55	43	32	12.6	6.7	50	65
65	155	64	46	32	12.6	6.7	50	65
80	162	72	46	32	12.6	6.7	50	65
100	181	90	52	32	15.77	10.3	70	90

125	197	101	56	32	18.92	10.3	70	90
150	210	114	56	32	18.92	10.3	70	90
200	240	145	60	40	22.10	14.3	102	125
250	286	178	68	40	28.45	14.3	102	125
300	309	204	78	40	31.60	14.3	102	125
350	ii	ii	ii	ii	ii	ii	ii	ii

NOTE:

Dimensions of "M", "L1", "L2", "D1" for the following Standard available: GB9112-88, DIN2501, BS4504, ISO2084, ISO2531, BS10-E, ANSI15/150, ASA125/150. AS2129 Table

## Butterfly Valve BV2000S

BV2000S is Wafer Butterfly valve without pin. The size is for 2" (DN50) to 14" (DN350). It is with soft seat and double D type disc. Valve body features four alignment holes at least. Valve can be mounted with handles (2" to 12"), Manual Gear Operators (2" to 14"), and electric or pneumatic actuators (2" to 14") Face to face dimension are available in GB 12238 BS5155 API609, MSS SP-76, DIN 3202-K1 (ISO 5762 T5).

Flange drilling are universal standard, suitable for DIN PN10/PN16 ANSI 125/150 JIS 10k as well.

Valve tested: API598

Safe working pressure: PN6,10,16.

**Fig: Butterfly Wafer Valve BV2000S**

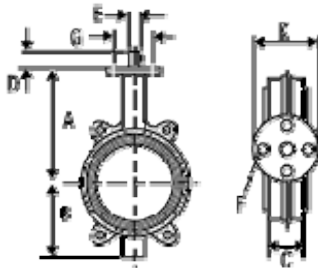

Dimensions and Weight

Size	A	B	C	D	E	F	G	K
50	143	55	43	32	12.6	6.7	50	65
65	155	64	46	32	12.6	6.7	50	65
80	162	72	46	32	12.6	6.7	50	65
100	181	90	52	32	15.77	10.3	70	90
125	197	101	56	32	18.92	10.3	70	90
150	210	114	56	32	18.92	10.3	70	90
200	240	145	60	40	22.10	14.3	102	125
250	286	178	68	40	28.45	14.3	102	125
300	309	204	78	40	31.60	14.3	102	125
350	ii	ii	ii	ii	ii	ii	ii	ii

NOTE:

Dimensions of "M", "L1", "L2", "D1" for the following Standard available: GB9112-88, DIN2501, BS4504, ISO2084, ISO2531, BS10-E, ANSI15/150, ASA125/150. AS2129 Table

### Butterfly valve BV2000L

BV2000L is Lug Butterfly valve. The size is for 2"(DN50) to 14" ( DN350). It is with soft seat and double D type disc. Valve body features four alignment holes at least. Valve can be mounted with handles (2" to 12"), Manual Gear Operators (2" to 14"), and electric or pneumatic actuators (2" to 14") Face to face dimension are available in GB 12238 BS5155 API609, MSS SP-76, DIN 3202-K1 (ISO 5762 T5). Flange Drilling are GB9112-88, DIN2501, BS4504, ISO2084, ISO2531, BS10-E, ANSI125/150, ASA125/150, AS2129 Table D/E. Valve tested: API598 Safe working pressure: PN6,10,16.

Fig: Butterfly Wafer Valve BV2000L

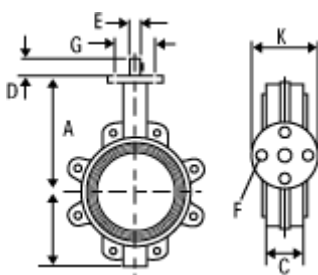

Size	A	B	C	D	E	F	G	K
50	143	60	43	32	12.6	6.7	50	65
65	155	68	46	32	12.6	6.7	50	65
80	162	73	46	32	12.6	6.7	50	65
100	181	102	52	32	15.77	10.3	70	90
125	197	122	56	32	18.92	10.3	70	90
150	210	131	56	32	18.92	10.3	70	90
200	240	160	60	40	22.10	14.3	102	125
250	286	188	68	40	28.45	14.3	102	125
300	309	220	78	40	31.60	14.3	102	125
350	ii	ii	ii	ii	ii	ii	ii	ii

NOTE:

Dimensions of "M", "L1", "L2", "D1" for the following Standard available: GB9112-88, DIN2501, BS4504, ISO2084, ISO2531, BS10-E, ANSI15/150, ASA125/150. AS2129 Table

### Butterfly Valve BV3000W

BV3000W is Slim-disc Butterfly valve and wafer type. The size is for 2"(DN50) to 14" ( DN350). It is with soft/back-up seat and double D or TD type disc without pin. Valve body features four alignment holes at least. Valve can be mounted with handles (2" to 12"), Manual Gear Operators (2" to 14"), and electric or pneumatic actuators (2" to 14") Face to face dimension are available in GB 12238 BS5155 API609, MSS SP-76, DIN 3202-K1 (ISO 5762 T5). Flange Drilling are GB9112-88, DIN2501, BS4504, ISO2084, ISO2531, BS10-E, ANSI125/150, ASA125/150, AS2129 Table D/E.

Valve tested: API598.

Safe working pressure: PN6,10,16.

**Fig: Butterfly Wafer Valve BV3000W**

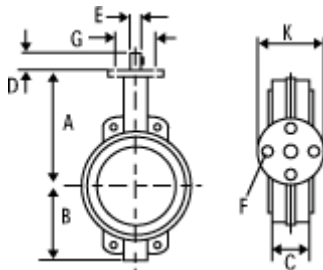

**Butterfly Valve Dimensions and Weight**

Size	A	B	C	D	G	E	K
50	139.7	79.3	41.5	32	50	12.6	65
65	152.4	85.6	44.5	32	50	12.6	65
80	158.8	96.2	44.5	32	50	12.6	65
100	178	109	51.4	32	70	15.77	90
125	190.5	117.5	54.4	32	70	18.92	90
150	203.2	137.8	54.4	32	70	18.92	90
200	251	140	63.5	40	102	22.10	125
250	268.3	190.5	67.7	40	102	28.45	125
300	306.4	222	77	40	102	31.6	125
350	368	267	78	40	125	31.6	150
400	400	298	102	51.2	140	33.15	175
450	422	318	114	51.2	140	38.00	175
500	480	349	127	64.2	140	41.15	175
600	562	440	154	70.2	165	50.65	210
700	624	520	163	66	254	55.00	300
800	672	591	188	66	254	55.00	300

**NOTE:**

Dimensions of "M", "L1", "L2", "D1" for the following Standard available: GB9112-88, DIN2501, BS4504, ISO2084, ISO2531, BS10-E, ANSI15/150, ASA125/150. AS2129 Table

**Butterfly valve BV3000L**

BV3000L is Slim-disc Butterfly valve and lug type. The size is for 2"(DN50) to 14" ( DN350). It is with soft/back-up seat and double D or TD type disc without pin. Valve body features four alignment holes at least. Valve can be mounted with handles (2" to 12"),Manual Gear Operators (2" to 14"),and electric or pneumatic actuators (2" to 14") Face to face dimension are available in GB 12238 BS5155 API609, MSS SP-76,DIN 3202-K1 (ISO 5762 T5). Flange Drilling are GB9112-88, DIN2501, BS4504, ISO2084, ISO2531, BS10-E, ANSI125/150, ASA125/150, AS2129 Table D/E.

Valve tested: API598

Safe working pressure: PN6,10,16.



**Fig: Butterfly Wafer Valve BV3000L**

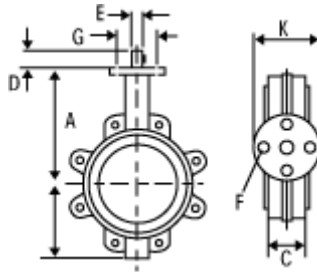

**Butterfly Valve Dimensions and Weight**

Size	A	B	C	D	G	E	K
50	139.7	79.3	41.5	32	50	12.6	65
65	152.4	85.6	44.5	32	50	12.6	65
80	158.8	96.2	44.5	32	50	12.6	65
100	178	109	51.4	32	70	15.77	90
125	190.5	117.5	54.4	32	70	18.92	90
150	203.2	137.8	54.4	32	70	18.92	90
200	251	140	63.5	40	102	22.10	125
250	268.3	190.5	67.7	40	102	28.45	125
300	306.4	222	77	40	102	31.6	125
350	368	267	78	40	125	31.6	150
400	400	298	102	51.2	140	33.15	175
450	422	318	114	51.2	140	38.00	175
500	480	349	127	64.2	140	41.15	175
600	562	440	154	70.2	165	50.65	210
700	624	520	163	66	254	55.00	300
800	672	591	188	66	254	55.00	300

**NOTE:**

Dimensions of "M", "L1", "L2", "D1" for the following Standard available: GB9112-88, DIN2501, BS4504, ISO2084, ISO2531, BS10-E, ANSI15/150, ASA125/150. AS2129 Table

**Butterfly valve BV4000**

BV4000W is Wafer Butterfly valve and we call it industry valve. The size is for 2"(DN50) to 14" ( DN350). It is with soft/back-up seat and double D or TD type disc without pin. Valve can be mounted with handles (2" to 12"), Manual Gear Operators (2" to 14"), and electric or pneumatic actuators (2" to 14") Face to face dimension are available in GB 12238 BS5155 API609, MSS SP-76, DIN 3202-K1 (ISO 5762 T5). Flange Drilling are GB9112-88, DIN2501, BS4504, ISO2084, ISO2531, BS10-E, ANSI125/150, ASA125/150, AS2129 Table D/E. Valve tested: API598 Safe working pressure: PN6,10,16.

**Model: Butterfly Valve Wafer Type (fig: BV4000W)**

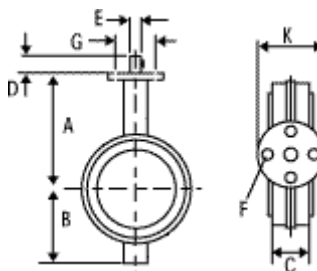

## Butterfly Valve Dimensions and Weight

Size	A	B	C	D	E	F	G	K
50	100	80	43	32	12.6	6.7	50	65
65	113	89	46	32	12.6	6.7	50	65
80	124	95	46	32	12.6	6.7	50	65
100	152	114	52	32	15.77	6.7	70	90
125	152	127	56	32	18.92	10.3	70	90
150	165	139	56	32	18.92	10.3	70	90
200	205	75	60	40	22.10	10.3	102	125
250	253	203	68	40	28.45	14.3	102	125
300	ii	ii	ii	ii	ii	ii	ii	ii
350	ii	ii	ii	ii	ii	ii	ii	ii

## Metal Sealed (Hard Sealed) Butterfly Valve Dimensions and Weight

### Model: Hard Sealed Butterfly Valve (fig: BV5000 W)

This kind of butterfly valve is suitable for use in Chemical, Oil, power generating, metallurgy industries and city heat-supply system as a flow adjusting and shutting unit.

- Safe and reliable in operation, high interference-resistance.
- Adopting design of double-eccentric, the friction on sealing ring may be decreased to extend service life.

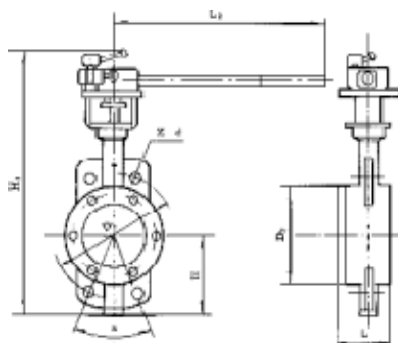

## Dimensions and Weight

Size (DN)	L	D1	D	Z-d	H	Ho	A	B	Wt/ kgs
50	43	125	165	4-18	112	460	355	92	16
65	46	145	185	8-18	115	480	355	92	18
80	49	160	200	8-18	120	490	355	92	24
100	56	190	235	8-22	140	632	550	138	29
125	64	220	270	8-26	170	678	550	138	37
150	70	250	300	8-26	180	743	550	138	41
200	71	310	360	12-26	210	690	250	170	52
250	76	370	425	12-30	240	767	450	220	68
300	83	430	485	12-30	290	950	450	280	80
350	92	490	555	16-33	320	1014	650	280	149
400	102	550	620	16-36	350	1070	650	280	248
450	114	600	670	20-36	380	1140	850	280	295
500	127	660	730	20-36	410	1220	850	380	360
600	154	770	845	20-39	470	1380	1250	380	480
700	165	875	960	24-42	550	1580	1250	380	620

## Specifications

Size	DN (mm)	50---14000	
Nominal Pressure	PN ( MPa)	1.0	1.6
Test Pressure PN (MPa)	Shell Test	1.5	2.4
	Seal Test	1.1	1.76
Suitable Medium	Water, Steam, Oil, Sea Water, Acids ect		
Suitable Temp	-40--- 570		



## Flanged Butterfly Valve Dimensions and Weight

### Soft--Seal Eccentric Flanged Short Body Butterfly Valve (fig: BV6000S) Soft--Seal Eccentric Flanged Long Body Butterfly Valve (fig: BV6000L)

- Flanged butterfly valves are also called double flange butterfly valves, they can be of double flange with short butterfly valves or with long butterfly valves.
- This valve can be used for water supply and drainage systems in water works, power generating factory, mill plant, paper-making, chemicals and foods industries, especially suitable for use as an ideal equipment for throttling or shutting off flow in water pipelines.
- Simple and compact in construction, light in weight, quick for on-off operation in 90 degree.
- The double eccentric structure reduces friction of the sealing ring, providing the valve a long service life .
- Replacing materials of the disc sealing ring "O" ring ,disc and shaft ,the valve can be used for various medium and temperature.
- Flange connection is in accordance with GB4216.1, -4216.4-84" Grey Cast Iron Pipe Flanges and Gaskets" and PN1.0 Mpa, PN1.6MPa flange-connection standard given in BS4504,ISO2084,DIN501.

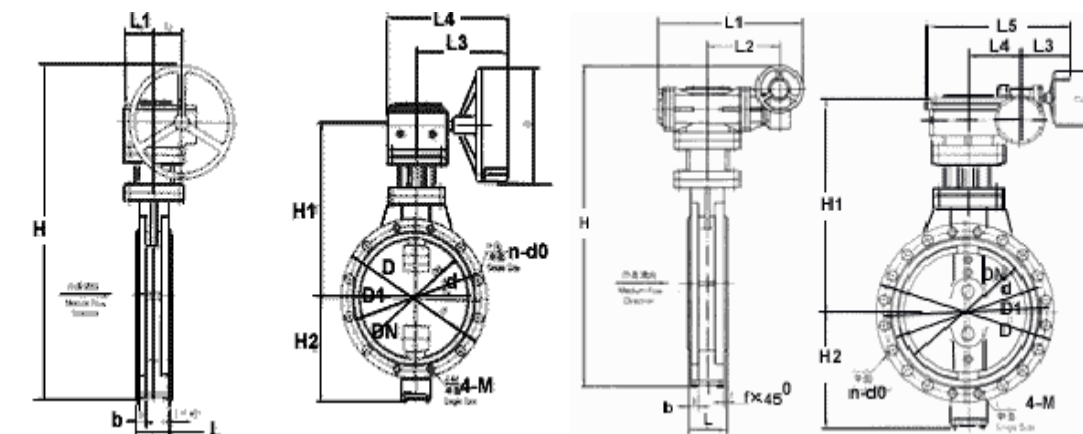

## Dimensions and Weight

Dimension for DN100---DN250																	
Size	D	D1	d	b	f	short body		long body	H	H1	L		L1	L2	L3	ii	L4
						n-d0	4-m	n-d0			short	long					
100	220	180	158	24	3	-	-	8-17.5	446	234	-	190	64	48	121	ii	180
150	285	240	212	26	3	-	-	8-22	521.5	279	-	210	74	58	128	ii	194
200	340	295	268	28	3	4-22	M20	8-22	690	349	89	230	80	70	163	ii	241
250	390	350	320	28	4	8-22	M20	8-22	800	406	114	250	98	95	193	ii	291
Dimension for DN300--DN1200																	
Size	D	D1	d	b	f	short body		long body	H	H1	L		L1	L2	L3	L4	L5
						n-d0	4-m	n-d0			short	long					
300	450	400	370	28	4	8-22	M20	12-22	959	542	114	270	449	178	254	104	473
350	505	460	430	30	4	12-22	M20	16-22	1048	583	127	290	449	178	254	104	473
400	565	515	482	30	4	12-22	M24	16-26	1120	620	140	310	449	178	254	104	473
450	615	565	532	34	4	16-26	M24	20-26	1190	667	152	330	449	178	254	104	473
500	670	620	585	34	4	16-26	M24	20-26	1280	702	152	350	486	196	254	130	528
600	780	725	685	35	5	16-30	M27	20-26	1409	759	178	390	627	244	254	162	596
700	895	840	800	40	5	20-30	M27	24-30	1613	885	229	430	627	244	254	162	596
800	1015	950	905	44	5	20-33	M30	24-33	1736	1013	241	470	635	270	295	196	711
900	1115	1050	1005	44	5	24-33	M30	28-33	1860	1071	241	510	635	270	295	196	711
1000	1230	1160	1110	50	5	24-36	M33	28-36	2107	1234	300	550	955	455	296	295	807
1200	1455	1380	1330	52	5	28-39	M36	32-39	2326	1343	350	630	955	455	296	295	807

### Grooved End Butterfly Valve PN16/Class150

**Valve Standards:** Complies with EN593/BS5155/MSS SP-67.

Complies with EN593/BS5155/MSS SP-67

#### Working Pressure and Temperature

Working pressure PN20/Class150.

Temperature from -10° to 120° for EPDM coated disc.

Temperature from -10° to 82° for NBR coated disc.

Temperature from -10° to 150° for Viton coated disc.

**Top Flange:** Complies with ISO5211/1.

#### Flange Types

Grooved dimensions comply with Metric or ANSI Pipe standards

**Operator:** Handle or gear operator.

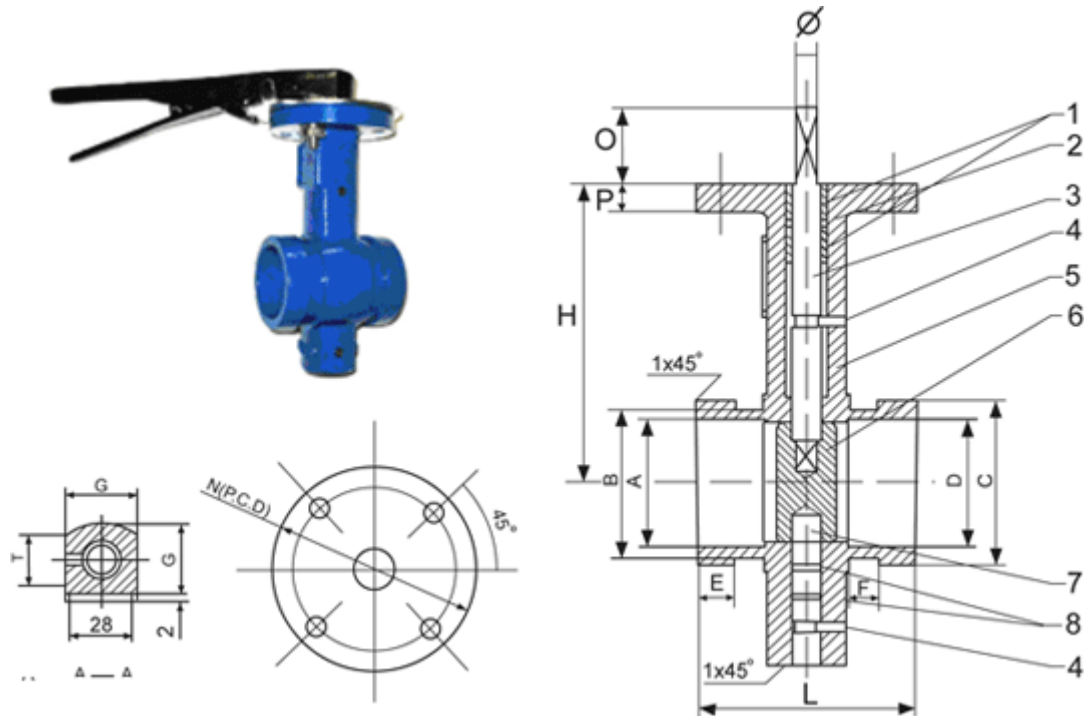

Item	Parts Name	Materials
1	Bushing	PTFE
2	O-Ring	NBR
3	Upper Spindle	410SS
4	Set Screw	CS M6
5	Body	CI
6	Disc	EPDM Coated DI
7	Lower Spindle	410SS
8	O-Ring	NBR

Size - mm	A	B	C	D	E	F	G	H	O	L	N	P
50	51	60.3	67	49.3	16	11	32	121	90	90	70	12
65	62.5	69.1	73	61	16	11	32	125.5	90	97	70	12
80	76	88.9	97	75	16	11	32	131.5	90	97	70	12
100	101	114	122.5	100	16	11	32	148.7	90	116	70	14
125	127	137	150	125	16	11	32	171.5	90	134	70	14
150	150	165	175	148	16	11	36	183	90	134	70	14
200	202	219	232	200	20.5	11	43	205.4	90	148	70	14
250	253	278	286	250	20.5	11	59	250	125	160	102	18
300	303	324	336.5	303	20.5	11	59	275	125	166	102	18
350	353	356	368.5	353	24	11	59	291	125	170	102	18

## Antiseptic Butterfly Valves and Wafer Check Valves



duo-plate-wafer-check-valve

worm-gear-flange-butterfly-valve

worm-gear-butterfly-valve

handle-flange-butterfly-valve

PTFE-lining-butterfly-valve

handle-butterfly-valve

## Butterfly valve Main Part Material

### Body of Material

Type of Material	Material Standard
Cast Iron	GG20 GG25, ASTM A126 Class B
Ductile Iron	GGG40, ASTM A536 60-40-18
Cast Bronze	ASTM B584 G90500
Stainless Steel	CF8M, CF8, ZG1Cr18Ni9Ti
Carbon Steel	WCB

### Disc Material

Ductile Iron (Nickel Plated or Nylon Coated)	ASTM A536 60-40-18 DI
Stainless Steel	SS410, SS304, SS316
Aluminum	Al-Bronze

### Stem Material

Stainless Steel	SS410, SS304, SS316
Cast Steel	WCB (chrome plated)

### Seat Material of Body Liner Material

Material	Temperature Ratio	
	°C	°F
Buna-N(NBR)	-12----85	+10----185
Buna-N(Abrasive Resistant)	-12----85	+10----185
Neoprene	-7----93	20----200
EPDM	-35----135	-30----275
EPDM (Food Grade)	-35----110	-30----230
Hypalon	-32----135	0----275
Vinton	-12----135	10---275
PTFE	4.4----121	40---250

Seat Materials are capable of standing lower temperatures without damage. However it would become hard and torques would increase. Some flow media may further rest published temperature limits or significantly reduce seat life.

### Valve Seating Torques (in Lbs.)

Valve Size		Standard Disc, Differential Pressure							
		125PSIΔP		150PSIΔP		200PSIΔP		285PSIΔP	
		Bushing		Bushing		Bushing		Bushing	
NPS	DN	Bronze	PTFE	Bronze	PTFE	Bronze	PTFE	Bronze	PTFE
2"	50	106	100	117	106	127	111	140	117
2.5"	65	152	150	166	163	181	176	195	1819
3"	80	213	207	230	220	248	322	265	244
4"	100	321	290	386	323	450	357	515	390
5"	125	481	423	598	481	715	540	832	598
6"	150	692	599	878	691	1063	783	1248	875
8"	200	1326	1060	1716	1183	2106	1307	2496	1430
10"	250	2239	1671	3010	1872	3780	2074	4550	2275
12"	300	3959	2568	4953	2795	5948	3023	6942	3250



14"	350	4881	2640	6226	3070	7570	3500	ii	ii
16"	400	7020	4260	8580	4880	10140	5500	ii	ii
18"	450	10105	6287	12202	7243	14300	8200	ii	ii
20"	500	13923	8360	16582	9180	19240	10000	ii	ii
24"	600	23617	15427	26953	16813	30290	18200	ii	ii
30"	750	39721	27313	43391	29407	47060	31500	ii	ii
32"	800	ii	ii	ii	ii	ii	ii	ii	ii
36"	900	ii	ii	ii	ii	ii	ii	ii	ii
40"	1000	ii	ii	ii	ii	ii	ii	ii	ii
48"	1200	ii	ii	ii	ii	ii	ii	ii	ii

The above torque values are only available for ANSI Class 125 Working pressure designed butterfly valves size from 2" to 30". Or for PN16 working pressure designed valves size from DN50 to DN300. All torque values shown on chart are for "wet" (water and other non-lubricating medium) on-off service. For "dry" service (non-lubricating, dry gas media), multiply values by 1.6. For "lubricating medium" service (clean, non-abrasive lubricating media), multiply values by 0.85. When sizing actuators for single valve applications, multiply values by 1.25. When sizing for 3-way ("tee") applications multiply values by 1.5.

Under certain conditions, hydrodynamic torque can meet or exceed seating and unseating torques. When designing valve systems, hydrodynamic torque must be considered to help ensure correct selection of application.

### Cv value of Butterfly Valve

The valve Cv is the flow rate (in US gal/min) of pure water at 600F passing through the valve when the valve disc is fully opened and the pressure differential between the two ends of the valve is 1 Lbf/in<sup>2</sup>

$$Cv = \sqrt{\frac{G}{P_1 - P_2}}$$

- V. Max. Flow (in us gal/min) G:
- Specific gravity (1 for water)
- P1: Inlet side pressure (Lbf/in<sup>2</sup>)
- P2: Outlet side pressure (Lbf/in<sup>2</sup>)
- Cv = 1.17C

Conversion of flow resistance coefficient and Cv value

$$Cv = 29.9 \frac{d^2}{\zeta}$$

- d: Valve bore size or valve seat bore size (in)
- ζ: Flow resistance coefficient (no unit)

Size		Flow in Gpm 1PSI ΔP Various Disc Angles								Full 90° open
inch	DN	10°	20°	30°	40°	50°	60°	70°	80°	
2"	50	0.1	5	12	24	45	64	90	125	135
2.5"	65	0.2	8	20	37	65	98	144	204	220
3"	80	0.3	12	22	39	70	116	183	275	302
4"	100	0.5	17	36	78	139	230	364	546	600
5"	125	0.8	29	61	133	237	392	620	930	1022
6"	150	2	45	95	205	366	605	958	1437	1579
8"	200	3	89	188	408	727	1202	1903	2854	3136
10"	250	4	151	320	94	1237	2047	3240	4859	5340
12"	300	5	234	495	1072	1911	3162	5005	7507	8250
14"	350	6	338	715	1549	2761	4568	7230	10844	11917
16"	400	8	464	983	2130	3971	6282	9942	14913	16388
18"	450	11	615	1302	2822	5028	8320	13168	19752	21705
20"	500	14	791	1674	3628	6465	10698	16931	25396	27903
24"	600	22	1222	2587	5606	9989	16538	26157	39236	43116





28"	700	36	1813	3639	6636	10000	14949	22769	34898	49500
32"	800	45	2387	4791	8736	13788	20613	31395	48117	68250
36"	900	60	3021	3063	11055	17449	26086	39731	60895	86375
40"	1000	84	4183	8395	15307	24159	36166	55084	84425	119750

## Detail Specification for Wafer & Lug Butterfly Valve

The valve is ideal for throttling or shutting off the flow of corrosive or incorrosive gases, liquids, semi-liquids and solid powder, and can be installed in pipelines or on vessels in the industries of petroleum processing, chemicals food, medicine, textile, paper making, hydroelectricity engineering, ship building, water supply and sewage, metallurgy, energy engineering as well as light industry etc.

- Small in size and light in weight. Easy installation and maintenance. It can be mounted wherever needed.
- Simple and compact construction, quick 90 degrees on-off operation. Minimized operating torque, energy saving.
- Long service life, Standing the test of tens of thousands opening/closing operations.
- Bubbles-tight sealing with no leakage under the pressure test
- Wide selection of materials, applicable for various medium.

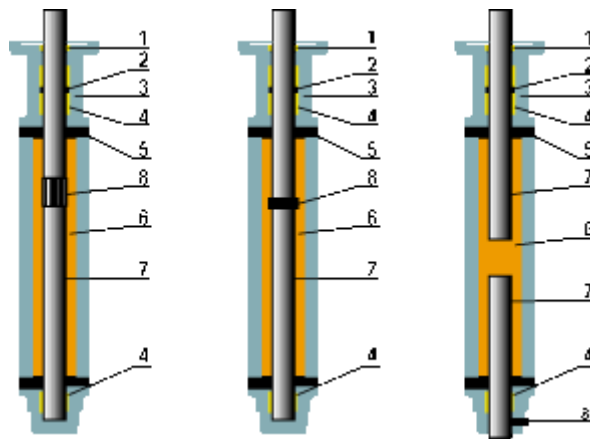

Item NO.	Name of Part	Performance Feature
01	Check Ring	Provides prevention of blow out of shaft
02	O-ring	Provides prevention of outside dust
03	Body	Precision Cast Iron Body or Ductile Iron Body, According with various connection standards
04	Bush	Furnishes stem support for positive stem alignment and actuator support
05	Seat	Bonded to body or inserted
06	Disc	Provides double-tight shut-off and assures minimum torque and longer seat life
07	Stem	Ensures dependability and positive disc positioning, blow out proof design stem
08	Splinted (Tapered pins)	Ensures positive shaft to disc connection, convenient for field replaceable, furthermore, Using of splint reduces possibility of leakage through disc and shaft

## Technical Data

Nominal Diameter	50(2")-2000(80")	50(2")--1000(40")	40(1 1/2")-2000(80")
------------------	------------------	-------------------	----------------------



Nominal Pressure	1.0 Mpa	1.6Mpa	0.6Mpa
Test Pressure	Shell 1.5Mpa Sealing 1.1Mpa	2.4Mpa 1.76Mpa	0.9Mpa 0.66Mpa
Working Temperature	-15----- +150		
Suitable Mediums	Fresh/Sewage/Sea Water, Gas, Vapor, Food, Medicine, Oils, Acids, Alkalis Salt, etc		

## Butterfly Valve Actuator

Pneumatic Actuator or Electric Actuator from famous Actuator Control Manufacturer are available on request.

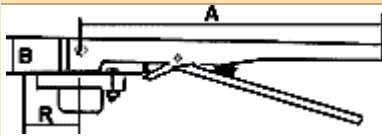
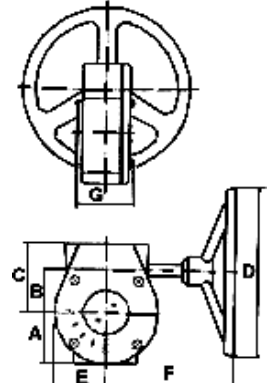
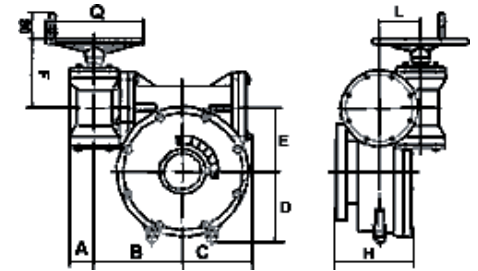
Dimensions/Weight of Ten-Position Lever											
	Size	A	B	R	Weight						
	50(2")-150(6")	266.7	32	52	0.9kg						
	200(8")-300(12")	359	50	75.2	2.3kg						
Dimensions of Worm Gear ( Single & Double-stage )											
	Size	A	B	R	Weight						
	50(2")-150(6")	266.7	32	52	0.9kg						
	200(8")-300(12")	359	50	75.2	2.3kg						
	Model	Size	A	B	C	E	F	G	D	Weight	
	3D-20	50-150	52	45	74	52	152.5	75	150	5.2kg	
3D-50	200-250	75	62.75	101	75	250	86	225	12kg		
3D-120	300-350	81	80	118	81	227	83	300	15kg		
Overall Dimensions & Weight of Double-stage wormgear Actuator:											
											
Model	Size mm	A	B	C	D	E	F	H	L	Φ	Weight
3D-30/250	400-500	56.5	178.5	121	115	104	174	125.5	66	300	56.9
3D-30/400	600	56.5	197.5	142	144	130	174	145.5	66	300	72.37
3D-60/800	700-800	67	244	183	189	162	165	157	88	400	124
3D-120/1500	900-1000	76	270	215	220	196	215	235	126	300	158

## Check Valves

### Wafer Check Valve Technical Data and Installation

**MODEL: WAFER CHECK VALVE (CW1000, CW2000, CW3000, CW4000)**

Wafer check valve is a general purpose and one way flow valve. Due to lighter in weight and short dimension, wafer check valve is very easy to be installed between flanges. Inner parts assembled by two semicircle springs and plates, which pinned to the body. Normally closed by spring action and open by fluid pressure. Because the spring cycle reaction is very quick, it could protect the pipe from wafer hammer.

#### Precautions in piping

- Lay pipes so that the cast direction of wafer check valve body corresponds with the flow direction.
- It can be installed in vertical piping. In horizontal piping, set the rib wafer check valve vertically.
- Use an extension tube between wafer check valve and butterfly valve, never connect the wafer check valve to the valve directly.
- Avoid entering the end of a tube or gasket within the operating of a radius of the wafer check valve discs.
- Never mount a reducer just in front of or behind the wafer check valve
- When installing a wafer check valve near an elbow, leave a space as large as possible between them.
- When installing a wafer check valve at a pump outlet, leave a space at least 6 times of valve diameter and be sure that the plate is evenly stressed by fluid.

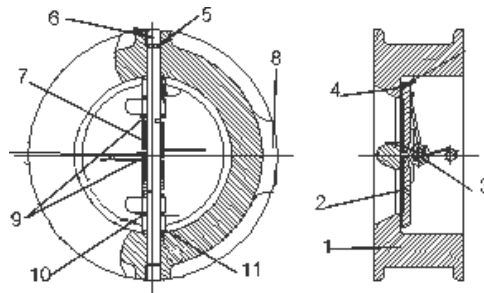

NO	Name Of Part
1	Body
2	Disc
3	Stem
4	Seat
5	Pin Retainer
6	Pin Stabilizer
7	Spring
8	Name Plate
9	Spring Bearings
10	Plate Bearing
11	Body Bearing

Normal Dia	50(2")-----700(28")	50(2")-----450(18")	mm (inch)
Nom. Pressure	1	1.6	Mpa
Test Press	Shell	2.4	
	Seal	1.76	
Working Tem (iãC)	-15-----+150		
Suitable Medium	Fresh water, Sewage, Sea water, Air, Steam, Food, Medicine, Oils, Acids, etc.		



## Dual Plates Wafer Check Valve

Wafer check valve ,we also call butterfly check valve, our CW1000 is a save-energy product, manufactured based on the foreign advanced technology and in accordance with relative international standards. This product is featured by excellent retaining performance, high safety and reliability and low flow resistance. It is suitable for systems in the industries of petrochemical, food processing, medicine, textile, paper-making, water supply and drainage, metallurgy, energy and light industry etc used a check valve in one way

MODEL: CW1000

1. Valve Design to API 594
2. Valve Test to API598. BS6755
3. Face to Face :EN558-1 Basic Series 16(Wafer Long ),GB12221-89

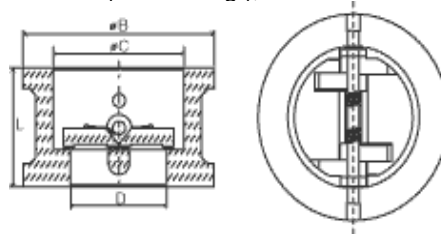

### Dimensions of CW1000(unit: mm)

Size	50	65	80	100	125	150	200	250	300	350	400	450	500	600
D	40	60	70	88	115	134	182	220	260	298	350	385	438	538
C	65	80	94	117	14	170	224	265	310	360	410	450	505	624
B	107	127	142	162	192	218	273	328	378	443	489	555	594	700
L	43	46	64	64	70	76	89	114	114	127	140	152	152	178

## Wafer Check Valve CW2000 series

is cast iron body, the face to face dimension is according to ANSI B16.1 125 . Valve test to API 598,BS6755. The safer working pressure are 10 lbs and 16 lbs. This kind of wafer check valve is used for preventing the back-going of medium in pipelines and equipments, and the pressure of medium will bring the result of opening and closing automatically. When the medium is back-going, valve disc will automatically close to avoid accidents.

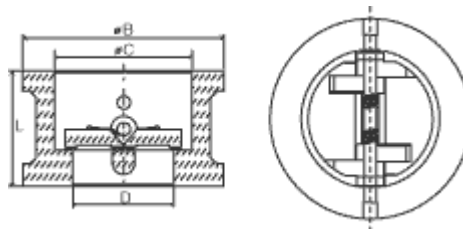

### Dimensions of CW2000 (unit: inch&kg)

Size	L	B	C	D	CV	Weight
2	2 1/8	4 1/4	2 5/16	1 9/16	80	6
2 1/2	2 1/8	5	2 7/8	1 7/8	90	7
3	2 1/4	5 9/16	3 1/2	2 7/16	150	10
4	2 1/2	6 3/8	4 1/2	3 5/32	300	14
5	2 3/4	7 9/16	5 9/16	4	500	19
6	3	8 3/4	6 5/8	5	900	25



8	3 3/4	10 3/4	8 5/8	7 1/2	1700	40
10	4 1/4	12 15/16	10 3/4	9 7/8	3000	70
12	5 11/16	15 1/8	12 3/4	11 1/8	4000	100
14	7 3/16	17 1/2	14 9/16	13	5350	140
16	7 15/16	20	16 9/16	14 1/8	7400	180
18	8 1/8	21 5/16	18 9/16	16	10000	250
20	8 3/8	23 1/2	20 7/16	19	13000	300
24	8 3/4	28	24 7/16	23	24000	420

### CW3000 is our new wafer check valve series.

The design of CW3000 is same with CW1000. But the body material is Cast Steel. Face to Face dimension is ANSI B16.1 CL150. It can work under 16 lbs. This wafer check valve is tightly sealed, without leakage under the pressure water test. Safe and reliable in operation, high interference-resistance.

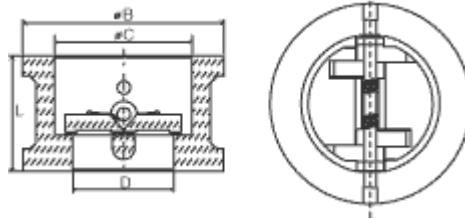

### Dimension of CW3000 (unit: inch&kg)

Size	A Diameter	L Face to Face	B Min FLG Bore	Weight
2	4.125	2.375	1.938	5.5
2.5	4.875	2.62	2.300	8
3	5.375	2.875	2.906	12
4	6.875	2.875	3.828	15
6	8.75	3.875	5.766	30
8	11.000	5.000	7.625	64
10	13.375	5.75	9.562	104
12	16.125	7.125	11.375	188
14	17.75	7.25	12.5	214
16	20.25	7.5	15	353
18	21.625	8	16.875	400
20	23.875	8.62	18.812	540
24	28.25	8.75	22.625	875

### Dual Plates Wafer Check Valve

Wafer Check valve CW4000 is the same design with CW2000. The different is the body material ,CW4000 is cast steel body. The safer working pressure is the highest among our all wafer check valve. It is ANSI B16.1 CL300. The valve design is to API 594.

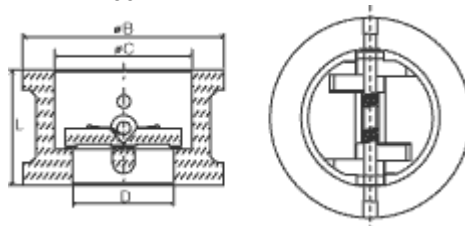

1. Body	2. Disc	3. Lower Holder
4. Upper Shaft	5. Lower Shaft	6. Connector
7. Spring	8. Upper Holder	ii

## Dimensions of CW4000( unit: inch&kg)

Size	A Diameter	L Face to Face	B Min FLG Bore	Weight
2	4.375	2.375	1.938	6
2.5	5.125	2.62	2.300	8
3	5.875	2.875	2.906	14
4	7.125	2.875	3.828	15
6	9.875	3.875	5.766	42
8	12.125	5.000	7.625	78
10	14.25	5.75	9.562	112
12	16.625	7.125	11.375	195
14	19.125	8.75	12.5	390
16	21.25	9.125	14.312	410
18	23.5	10.375	16.875	660
20	25.75	11.5	17.937	810
24	30.5	12.5	21.562	1300

## Dual Plates Wafer Check Valve

Wafer Check valve CW4000 is the same design with CW2000. The different is the body material ,CW4000 is cast steel body. The safer working pressure is the highest among our all wafer check valve. It is ANSI B16.1 CL300. The valve design is to API 594.

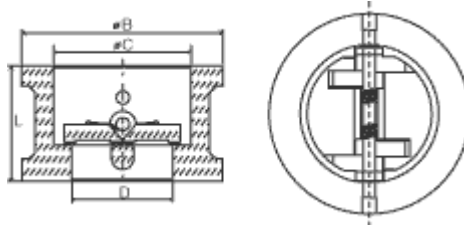

1. Body	2. Disc	3. Lower Holder
4. Upper Shaft	5. Lower Shaft	6. Connector
7. Spring	8. Upper Holder	ii

## Dimensions of CW4000( unit: inch&kg)

Size	A Diameter	L Face to Face	B Min FLG Bore	Weight
2	4.375	2.375	1.938	6
2.5	5.125	2.62	2.300	8
3	5.875	2.875	2.906	14
4	7.125	2.875	3.828	15
6	9.875	3.875	5.766	42
8	12.125	5.000	7.625	78
10	14.25	5.75	9.562	112
12	16.625	7.125	11.375	195
14	19.125	8.75	12.5	390
16	21.25	9.125	14.312	410
18	23.5	10.375	16.875	660
20	25.75	11.5	17.937	810
24	30.5	12.5	21.562	1300

### Thin Wafer Swing Check Valve (Single Plate Wafer check valve)

MODEL: Wafer Check Valve-----CW6000 Series

Wafer Design with or without spring closing

Valve design to ANSI125 ---- ANSI 600 design

Extremely low crack opening pressure

Extremely low pressure drop

Efficient flow characteristic

Short overall length wafer design

Centering achieved by means of body outside diameter

Standard Elastomer Seating or metal and metal seating provided.

Single plate wafer check valve with spring loaded or non spring loaded available.

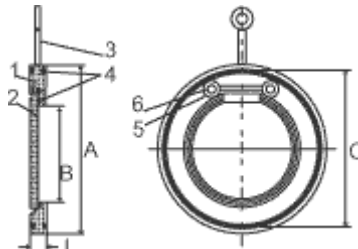

1.Body	2.Disc and Shaft	3.Eye Bolt
4.O-Ring	5.Bolt	6.Washer

#### Material of Parts

Body	Stainless Steel
Disc	Stainless Steel
O-Ring	Viton
Bolt, Washer	SS316
Eye Bolt	SS304

#### Dimensions of CW6000(unit: mm)

Size	B	A				L				C	Weight
		CL.125	CL.150	CL300	CL600	CL125	CL150	CL300	CL600		
DN40	23	87	87	95	95	19	19	19	19	76.5	ii
DN50	33	104	104	111	111	19	19	19	19	93	ii
DN65	41	124	124	130	130	19	19	19	19	113.8	ii
DN80	54	136	136	149	149	19	19	19	19	128	ii
DN100	71	174	174	180	193	19	19	19	22	144.5	ii
DN125	92	197	197	ii	ii	ii	ii	ii	ii	173.5	ii
DN150	112	222	222	250	266	19	19	22	28	197.4	ii
DN200	155	279	279	307	620	28	28	28	38	245.5	ii
DN250	201	339	339	362	400	28	28	38	57	306.5	ii
DN300	240	409	409	422	457	38	38	51	60	357.5	ii
DN350	270	450	450	485	192	44	44	51	67	408.5	ii
DN400	311	514	514	539	565	51	51	51	73	456.5	ii
DN500	360	549	549	696	612	60	60	76	83	498.5	ii
DN600	410	606	606	654	582	64	64	83	92	550.5	ii



### Order code

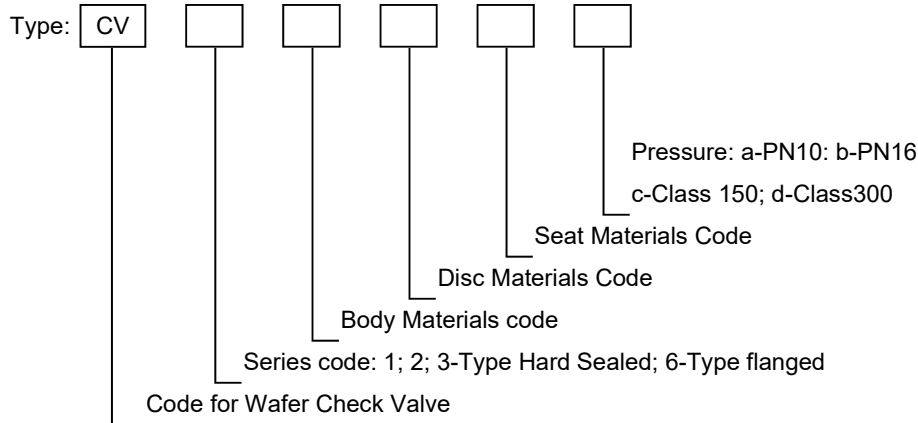

### Code for Main Parts Materials

D.I. --Ductile Iron; ?C.I. -- Cast Iron; A.B.--Aluminum Bronze

Body	Mat.	Cast Iron		Ductile Iron		WCB	Stainless Steel	
	Code	1		2		3	4	5
ii								
Disc	Mat.	Plated D.I.		Plated WCB		Ti. Steel	Stainless Steel	
	Code	1		3		2	4	5
Seat	Mat.	NR	Hypalon	EPDM	Neoprene	NBR	Viton	
	Code	1	2	3	4	5	6	
Stem	Mat.	Plated WCB		Stainless Steel				
	Code	3		410	304	316		
Bush	Mat.	Lubrized Bronze		PTFE				
	Code	1		7		ii		

### Cast Iron Swing Check Valve Bolted Bonnet Renewable Seat Flanged Ends

**MODEL: Swing Check Valve CS-01**

Valve Design to MSS SP-71,BS5153 / Flange to EN1092-2,GB9113,GB4612.4.BS4504 / Face to Face:  
EN558-1 Basic series 1,GB12221,DIN3202F1  
Safe Working Pressure: PN10,PN16 / Suitable Medium: Water, Oil, Gas

## MODEL: Swing Check Valve CS-02

Valve Design to MSS SP-71,BS5153 / Flange to ANSI B16.1 CLASS125,150 / Face to Face: ANSI B16.1 CLASS125, BS5153 / Safe Working Pressure: PN10,PN16 / Suitable Medium : Water, Oil, Gas

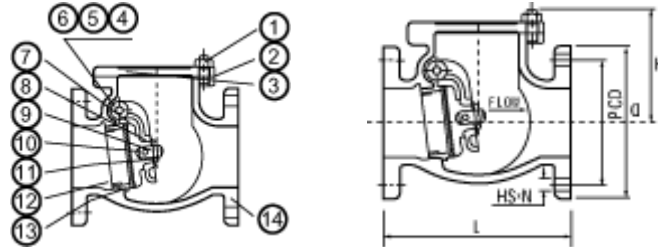

ii	Part Name	Material
1	Bolt & Nut	Steel
2	Gasket	Synthetic Fiber
3	Body Cover	Cast Iron
4	Side Plug	Brass
5	Hinge Pin	Stainless Steel
6	Hinge Pin Seal	Synthetic Fiber
7	Hinge	Cast Iron
8	Washer	Steel/Brass
9	Split Pin	Steel
10	Disc	Bronze
11	Disc Nut	Brass
12	Disc Seat	Bronze
13	Body Seat	Brass
14	Body	Cast Iron

### Swing Check valve CS-01 Dimensions ( unit: mm )

Size	50	65	80	100	125	150	200	250	300
L	230	290	310	350	400	480	600	730	850
D	165	185	200	220	250	285	340	395/405	445/460
H	109	126	136	153	180	205	242	330	385

### Swing Check valve CS-02 Dimensions ( unit: mm )

Size	50	65	80	100	125	150	200	250	300
L	203	216	241	292	330	356	495	622	698
D	152	178	191	229	254	279	343	406	483
H	109	126	136	153	180	205	242	330	385

## Lift Check Valve

The components of lift check valve are made of high quality copper alloy, Teflon, and stainless steel, which are excellent corrosion and abrasion resistant. This check valve may be mounted in vertical or horizontal position also compact and lightweight design gives ease of installation, service and maintenance, and reduces installation time.



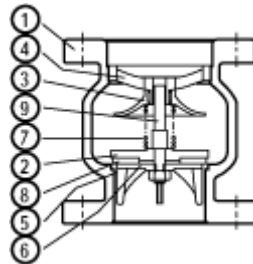

NO	Name of Part	Material
1	Body	Cast Iron
2	Disc Holder	Cast Iron
3	Buffer	Cast Iron
4	Upper Guide	Ductile Iron
5	Seat Ring	Bronze
6	Disc Washer	Steel Plate
7	Spring	SS304
8	Soft Seat	NBR
9	Hinge Stem	SS400

#### Technical Data

Applicable Fluid	Water, Oil
Applicable Inlet Pressure	Max, 10kgf/cm <sup>2</sup>
Applicable Temperature	Max, 80jæ(Special Order : Max 120jæ)
Min, Pressure Differential across the Disc	0.05-----0.1 kgf/cm <sup>2</sup>
Leakage Allowance	0
End Connection	Flanged
Hydrostatic Test	15kgf/cm <sup>2</sup> ----- 3 min

#### Lift Check Valve

Non Slamming.  
 Spring closing for positive leak tight closing.  
 Lighter, Smaller, Robust, Less expensive, Easy to install and maintain. Installation between flanges.  
 Installation in any place and direction.  
 Very low opening pressures.  
 Valves are Self contouring type.  
 Valves available in soft & metal to metal seat.  
 Zero leakage for Soft Seated Valve.  
 Testing as per API 598 or as per clients requirement.  
 Available in PN 10 and ANSI 125 rating.

**MODEL: Lift Check Valve CL-01, Flange to Specification: JIS 10K FF, Face to Face: JIS 10K**

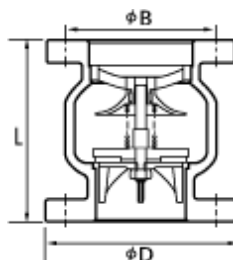



## Dimensions of CL-01( unit: mm )

Model	CL-01		
Size	L	D	B
40	150	140	40
50	175	155	50
65	185	175	65
80	195	185	80
100	200	210	100
125	254	250	125
150	280	280	150
200	368	330	200
250	400	400	250
300	460	445	300

## Smolensky Check Valve

The smolensky check valve is the lift check valve added by pass. It can make a function of harmless check valve, dashpot check valve.

- Water Hammer!-The Enemy of Flow Pipeline

The water hammer occurs by sudden flow stopping caused by pump-off or pressure wave caused from the pipes bending.

- Smolensky check valve --- No Impact , No Dining.

This commodity is the superb check valve designed to prevent the water impact with the operation of buffer hill&spring inside, thereby the water hammer&breakage of the pipes can be protected.

- Theory of Operation

When the pump starts, the pressure of the fluid pushes disc(2)then the fluid flows to chamber (c) through the chamber (A) &(B). When the pump stops, momentarily the pressure in the pipeline falls down then the short stagnation of the flow occurs and the reverse flow follows soonest. But at the same time by the action of spring(1)&buffer hill (4)disc(2) adheres to body seat(3)therefore any reverse flow&water hammer can be prevented.

- Advantage

- No water hammer
- No trouble by the simple structure
- Easy repair
- When the repair or replacement of the pipe is done, the water in the body champer is drained by the attached by-pass valve.
- No impact &noise
- Scrupulous &safe check
- No leakage
- Available for the vertical and horizontal piping connection
- Body and other part materials can be selected by customers' requests & sites' conditions

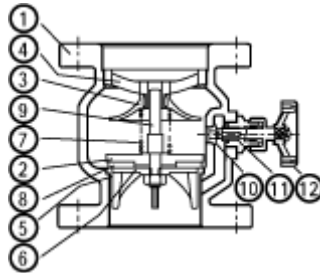

No	Name of Part	Material
1	Body	Cast Iron
2	Disc Holder	Cast Iron
3	Buffer;j	Cast Iron
4	Upper Guide	Ductile Iron
5	Seat Ring;j	Bronze
6	Disc Washer	Steel Plate
7	Spring	SS304
8	Soft Seat;j	NBR
9	Hinge Stem;j	SS400
10	Bypass	Brass
11	Bypass	Brass
12	Handle	Ductile Iron

### Technical Data

Applicable Fluid	Water, Oil
Applicable Inlet Pressure	Max, 10kgf/ cm <sup>2</sup>
Applicable Temperature	Max. 82;æ(Special Order :Max 120°C)
Min, Pressure Different across the Disc	0.05-----0.1kgf/cm <sup>2</sup>
Leakage Allowance	0
End Connection	Flanged
Hydrostatic Test	15kgf/cm <sup>2</sup> ---- 3min

ii

## Smolensky Check Valve (Lift Check Valve Added By Pass)

**MODEL: Smolensky check valve ( CL-02)**

Flange to Specification: JIS 10K FF,

Face to Face: JIS 10K

Safe Working Pressure: PN10

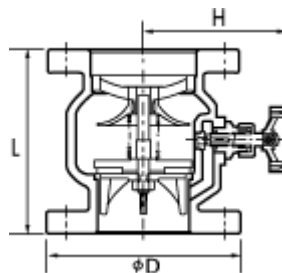

## Dimensions of Smolensky check valve ( unit: mm)

Model	CL-02		
Size	L	H	D
40	150	122	140
50	175	125	155
65	185	137	175
80	195	147	185
100	200	155	210
125	254	175	250
150	280	185	280
200	368	220	330
250	400	260	400
300	460	280	445

## Balance Valve

### SPF(SP) Series Numerical-Locked Balance Valve

SPF(SP) series numerical-locked balance valve is mainly used in liquid pipelines of water power working conditions. It has excellent regulating function, cutting-off function, the valve opening display unit and the valve opening locked function as well. When Used in heating supply system and air-conditioning water system, the valve helps to save heat and electric energy. Due to its excellent service, PF(SP) series numerical-locked balance valve is one of the best regulating valves made-in-China, as a professional manufacturer and experienced world-wide supplier, we enjoy good reputations among our global customers.



#### Function and characteristics:

- Excellent regulating function;
- Excellent cutting off function;
- The display precision of the valve opening is up to 1/10 revolution;
- The characteristic curve of theoretical flow is (approximately) uniform percentage characteristic, when the valve opening is 30%-50%, the actual flow characteristic is linear;
- The valve opening locked function, thus, non-property management staff cannot change the set state.
- Pressure and flow can be regulated conveniently and effectively; the intelligence instrument, which shows the working pressure differential and the flow to the users' convenience, can guide and record the balancing and regulating schemes as well;
- Teflon sealed, the sealing is reliable and durable;
- According to the percentage of the valve opening and pressure differential, the valve flow can be calculated;
- The internal components are made of stainless steel, copper alloy, the anti-rust performance is better;
- It is not necessary to preset the operating space for the internal lift stem;

- Materials of valve body:  
DN15-DN300 Gray Cast Iron;  
DN350-DN600 Carbon Cast Steel;



## DN15-DN32 Forging Pressed Copper Alloy

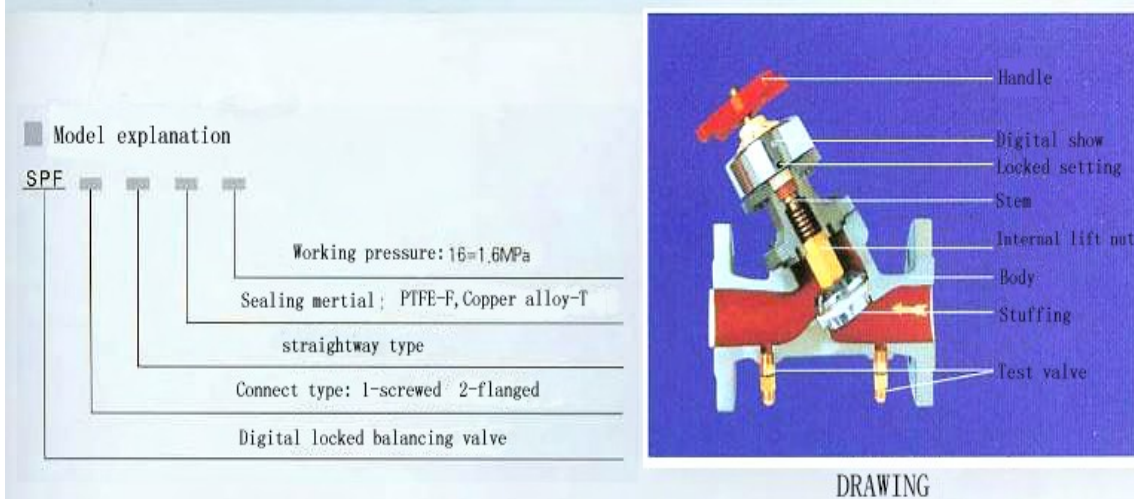

### SPF(SP) Series Numerical-Locked Balance Valve

#### SPF 15-10/16

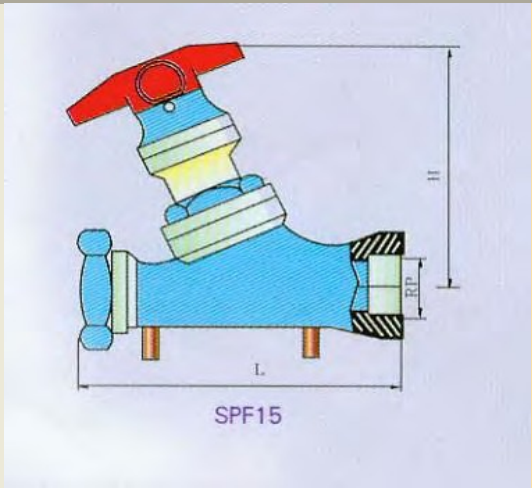
	Rp	L	H
			
DN			
15	1/2	90	110
20	3/4	115	120
25	1	125	125
32	5/4	140	130
40	3/2	160	140

#### Configuration

- SPF15T-16 numerical-locked balance valve is equipped with inclined stem, internal lift, teflon-sealing. The body material is forging pressed copper alloy.
- Two small pressure gauge/test valves are mounted at both sides of the balance valve. By using hose they are connected with the intelligence instrument, which shows the pressure differential and flow of the valve well and truly. The pressure differential can be measured by using other methods too, then the flow can be figured out as well.



## Connection Dimensions

	L	H	Rp	
	DN			
	15	90	76	1/2
	20	100	77	3/4
	25	110	81	1
32	120	108	5/4	

## Key Technical Parameter

Content	Testing	Nominal	Working	Applicable
	Pressure	Pressure	Temperature	Medium
Para.	2.4MPa	1.6MPa	≤150°C	Water Other liquids

## Flow Coefficient Table

DN	Opening (Revolutions)				
	1	2	3	4	5
DN15	0.5	1.3	1.7	2.0	
DN20	0.7	1.8	2.8	3.5	
DN25	1.0	2.5	3.5	4.6	
DN32	2.5	5	8	11	15

**SPF(SP) Series Numerical-Locked Balance Valve**  
**SPF45-16**

DN	D	D 1	D 2	L	H
32	135	100	76	180	130
40	145	110	84	200	140
50	160	125	102	230	195
65	180	145	122	290	220
80	195	160	130	310	230
100	215	180	158	350	260
125	245	210	184	400	290
150	280	240	212	480	330
200	335	295	268	495	530
250	405	355	320	622	560
300	460	410	370	698	590
350	520	470	435	787	780
400	580	525	485	914	830
500	705	650	608	978	880
600	840	770	718	1295	965

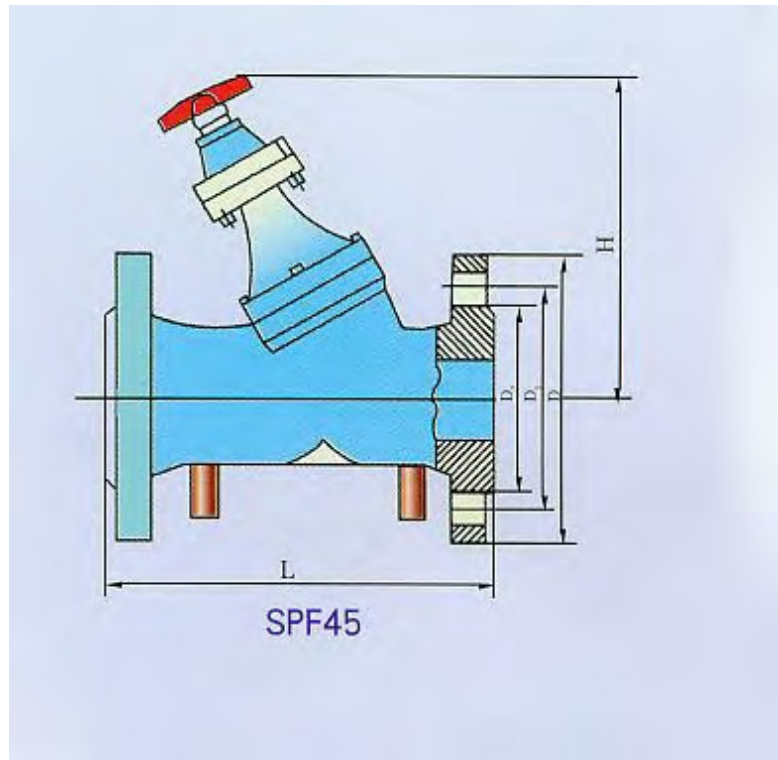

SPF: NUMERICAL LOCKING BALANCE VALVE, FLANGE END  
SEALING MATERIAL : PTFE, COPPER ALLOY  
NOMINAL PRESSURE : 1.6MPa  
TECHNICAL PARAMETERS:

Item	Parameter	Remarks
TEST PRESSURE	2.4MPa	
NOMINAL PRESSURE	1.6MPa	
WORKING TEMP.	≤150°C	
MEDIUM	WATER,OIL	

**SPF(SP) Series Numerical-Locked Balance Valve**

**The explanation of the following diagrams**

According to the formula:  $Kv=Q/\sqrt{\Delta P}$  , Q-m<sup>3</sup>/h, ΔP-100kpa (1kgf/cm<sup>2</sup>).

**Example 1** : When the flow Q and ΔP are known, that is Q=20m<sup>3</sup>/h, ΔP=30kpa, the diameter and the opening can be obtained by following this procedure:

Obtain the numerical values on Q-axis and ΔP-axis and draw a line between the two numerical values, then the point of intersection between the line and Kv-axis can be obtained. Draw a horizontal line which starts from the point of intersection. The the horizontal line will intersect with the valve opening scales of



DN50, DN65, DN80, then the valve opening obtained are 74%, 46%, 20%, that means the balance valve can select any one from among the above-mentioned three diameters (See Diagram 1).

**Example 2** : when the flow  $Q$  and diameter and the valve opening are known, that is  $Q=25 \text{ m}^3/\text{h}$ , DN65, the valve opening is 90%, the pressure differential  $\Delta P$  can be obtained as follows:

Draw a horizontal line which starts from the point of 90% opening of DN65. The point of intersection between the horizontal line and  $K v$ -axis can be obtained. Draw a line between the point of intersection and the point of  $25 \text{ m}^3/\text{h}$  on  $Q$ -axis and extend the line to  $\Delta P$ -axis, then  $\Delta P=8.0\text{kpa}$  can be easily figured out (See Diagram 2).

**Example 3** : when  $\Delta P$ , diameter and the valve opening are known, that is  $\Delta P=35\text{kpa}$ , DN32, the valve opening 80%, the flow can be obtained as follows:

Draw a horizontal line which starts from the point of 80% opening of DN32. The point of intersection between the horizontal line and  $K v$ -axis can be obtained. Draw a line between the point of intersection and the point of  $35\text{kpa}$  on  $\Delta P$ -axis and extend to  $Q$ -axis, the flow rate=  $7.4 \text{ m}^3/\text{h}$  can be obtained (See Diagram 3).



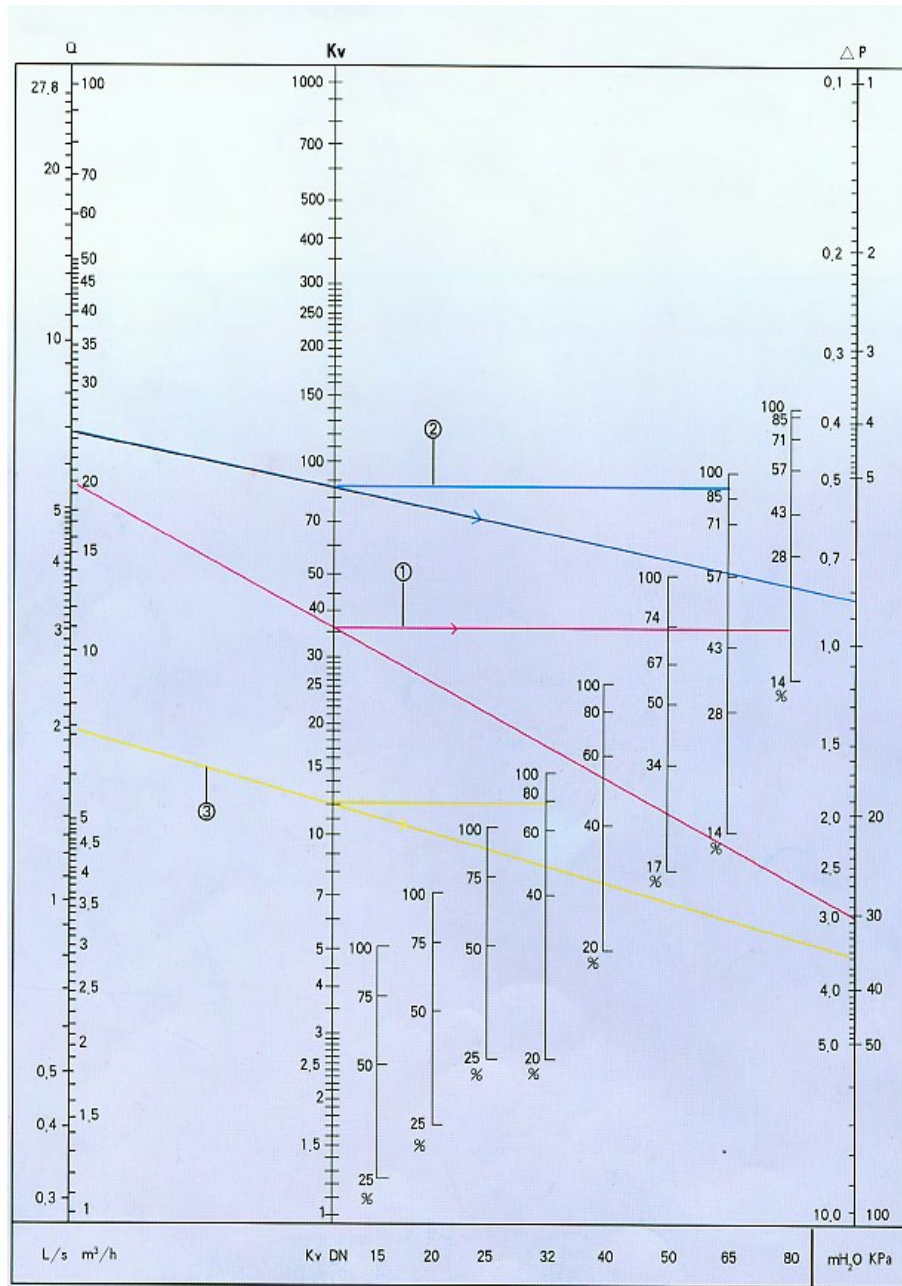



## Multifunctional Valve

As a professional supplier and manufacturer in China, our multifunctional valve is three valves in one.

- A calibrated balancing valve
- A shut-off valve
- A center-guided non-slam check valve
- We also can make the multifunctional valve with five functions according to customers' requirements, such as, adding a by pass or a mesh. If it is equipped with a mesh, it can function as a strainer. If it is equipped with a bypass, it can function as a dashpot valve.

Replacing three valves with just one multifunctional valve can dramatically lower your up-front materials and labor costs.

Main Features/Advantages:

- 1) The streamlined design of the multifunctional valve results in low pressure drop, making it extremely energy efficient.
- 2) Three valves in one reduces the cost to the minimum.
- 3) Greater range of control enable customers to get precise flow control in comparison with on-off throttling valves.
- 4) Positive shut-off without valve chatter.
- 5) Calibrated nameplate allows the return of valve to the balance position after shut-off.
- 6) Durable bronze seat, stainless steel stem and bronze disc construction guarantee a long service lifetime.

Balancing is obtained to improve the performance of a closed circuit, with forced circulation water systems for heating & cooling because of the variation in water flow in different systems. Balancing enables the plant to provide the desired indoor climate under all operating conditions, at minimum energy cost & with a modest input of time & labor. Balancing is achieved by adjusting pressure drop in order to get precisely the right flow of water at all times. Balancing reduces energy costs by almost 10% to 40%, by reducing average temperature in heating & by increasing average temperature in cooling, therefore, the fall in energy consumption of pumping is realized.

In order to attain hydraulic homogeneity & comparability throughout the plant, production & distribution including controlled circuits have to be balanced.

The Multifunctional Valve is a double-regulating, control and shut-off valve with built-in pressure drop measuring (in line flow measuring) facility. Balancing problems are quite evident in a multi-user systems, like central air conditioning plants and in process heat exchangers. The multifunctional valve is a combination of a shut-off valve (gate/plug/ball/butterfly Valve) plus flow regulating valve (globe valve) and flow measuring station and also a drain cock (available in bronze valves only). It is not merely a valve but also a system in itself. It provides a scientific basis for flow balancing in a system with database. The multifunctional valve can be set in pre-regulated flow conditions for tamper-proof positioning by a built-in locking device. The multifunctional valves are extensively used in HVAC systems and other process applications wherever balancing problems exist.

### The multifunctional valve

#### *Design Features*

The multifunctional valve is a Double Regulating, Control and Shut-off Valve with built-in pressure drop measuring (in line flow measuring) facility. Balancing problems are quite evident in a Multi-User systems, like Central Air Conditioning Plants and in Process Heat Exchangers. The Valve is a combination of a Shut-Off Valve (Gate/Plug/Ball/Butterfly Valve) plus Flow Regulating Valve (globe Valve) and Flow Measuring Station and also a Drain Cock (available in Bronze Valves only). It is not merely a Valve but a system in itself. It provides a scientific basis for Flow Balancing in a system with database. The Valve can be set in pre-regulated flow conditions for Tamper-Proof positioning by a Built-in Locking Device. The Valves are extensively used HVAC systems and other process applications wherever balancing problems exists.

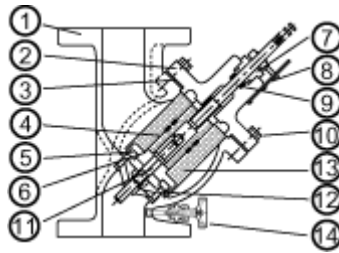

## The Multifunctional Valve TO-01 Specification

Part No.	Name of Part	Material
1	Body	Cast Iron
2	Bonnet, Cover	Cast Iron <sub>ii</sub>
3	Cover O-ring	Rubber
4	Spring	Stainless Steel
5	Disc Rubber	NBR
6	Disc Holder	Cast Iron
7	Packing	Bronze <sub>ii</sub>
8	Indicator	Iron <sub>ii</sub>
9	Valve Stem	SS304 <sub>ii</sub>
10	Cover Bolt	SS304
11	Hinge Stem	Stainless Steel
12	Packing	Cast Bronze
13	Screen	SS304
14	Bypass	Brass

## TO-01 Technical Data

ii	TO-01
Applicable Fluid	Water, Oil
Applicable Inlet Pressure	Max, 10kg/cm <sup>2</sup>
Applicable Temperature	Max, 82;æ (Special Order: Max 120;æ)
Min, Pressure Differential across the Disc	0.04----0.07kgf/cm <sup>2</sup>
Leakage Allowance	0
End Connection	ANSI B16.1 CL125, BS4504 PN10
Hydrostatic Test	15kgf/cm <sup>2</sup> -- 3min

## The Multifunctional Valve

User's complaints about unbalanced, hot or cold in different parts of the building are avoided.

System design and installation error are easily corrected.

Once completed a system hardly ever works exactly the way it was desired.

Methods of calculation of pressure drop and flow rates are often inaccurate or inaccurately applied.

System components like boilers/chillers, circulation pumps, valves etc. do not have to be oversized for possible errors and varying conditions" Just to be on the safe side".

A balanced system do not need such "reserves" only, but needs the actually required flow usually less than a system which is not balanced and can thus save heating/cooling energy.

The multifunctional valve often replaces system components selected for system design, by other brands or types, which may have different characteristics. The entire system design may thus become more or less inaccurate.

## The Multifunctional Valve (TO-01,TO-02,TO-03)

Face to Face : EN558-1 Basic series 1, GB /T 12221-1,DIN3202 F1, BS4504 PN10

Safe Working Pressure: PN10



**MODEL:** The multifunctional valve TO-01(Three-one Multipurpose valve)  
It can play as Calibrated balancing valve, shut-off valve, center-guided non-slam check valve

**MODEL:** The multifunctional valve TO-02( Four-one Multipurpose valve)  
It can play as Calibrated balancing valve shut-off valve, center-guided non-slam check valve and strainer.

**MODEL :** The multifunctional valve TO-03 ( Five-one Multipurpose valve)  
It can play as Calibrated Balancing valve, shut-off valve, center-guided non-slam check valve, strainer and dashpot valve.

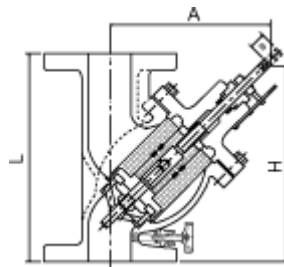

**Dimensions of Multifunctional Valve(TO-01,TO-02,TO-03)**

ii	50A	65A	80A	100A	125A	150A	200A	250A	300A
L	230	290	310	350	400	480	600	730	850
H	230	261	302	342	398	420	495	ii	
A	185	207	239	275	325	370	410	ii	ii

## Gate Valves

*Gate valves* can be left open, or closed, on a variety of water, gas and chemical duties for long periods with the guarantee of satisfactory operation as required. With easy, reliable, safe operation, clearance sealing and easy installation and maintenance, it can effectively control and prevent the disk from erosion.; Attempting fine control or throttling may lead to serious gate erosion. Overhead clearance for high steam, high lift valves is needed for installation and maintenance. Service with heavy solids in suspension could be troublesome-possibly creating seat wear and shut-off problem. A multi-turn valve has a gate-like disk and two seats to close the valve. The gate moves linearly, being perpendicular to the flow direction. This type of valve is normally used in the fully opened or fully closed position. It is not suitable for throttling applications. Gate valves provide robust sealing and are used extensively in the petrochemical industries. This type of valves also includes knife gate valves, conduit gate valves and wedge gate valves. Knife gate valves have much thinner gates with a knife-like edge, making them suitable for floating solids, e.g., such as in the pulp & paper industries. Conduit gate valves have a rectangular disc as the closing element. One half of the disk is solid, which is used to close the valve, the other half has a circular port, which is used to open the valve. Wedge gate valves have a wedge-shaped gate which "wedges" between floating seats and close the valve tightly.

A guillotine valve has been preferred to a spherical valve concept which implies a too long stroke for the filter. The closing and locking operations of the valve is as follows; first, the gate valve is pushed by a screw driven by the motor, from its retracted position towards closed position. When the gate valve reaches this position (the extremity of the caplet against the body), the internal mechanism of the gate valve activated by the screw makes its thickness increase until the movement is stopped by the main body of the valve.

Our **Top Flow Rubber Seated Gate Valves** are manufactured with the care and craftsmanship you can expect from a company that specializes in designing and manufacturing valves for petroleum industry.

All Top Flow products are designed and tested to ensure reliability and integrity for long-term safe operation. They are also engineered, manufactured and tested under our ISO 9001 Certified Quality Program. All valves are subject to visual inspections, pressure testings and all critical dimensions and specifications are guaranteed to meet API and ANSI codes. All materials used in the manufacturing process meet or exceed ASME and ASTM specifications.

Every Gate Valve features easy-to-replace seats that ensure tight sealing, even under the most rigorous field conditions. From design to manufacture and testing, we are one of the best supplier and manufacturer of gate valves made-in-China. **Our Top Flow Rubber Seated Gate Valves** are built for reliable and safe performance in the field.

Major applications:

- Wellheads;
- Pipelines and manifolds ;
- Drilling and chemical treatment;
- Oil, gas and water pipelines;
- Sour gas and crude oil;
- Abrasive and corrosive mud, cements, slurries and water flood;

## Cast Iron Gate Valve NRS Solid Wedge Disc Flanged Ends

### Description

1. Conforms to MSS SP-70
2. Flanges drilled to ANSI B16.1 (125lb)
3. Face to face dimensions conform to ANSI B16.1(125lb)
4. Working pressure:125S,200WOG
5. Suitable media: water, oil, gas.
6. Construction available in all iron.

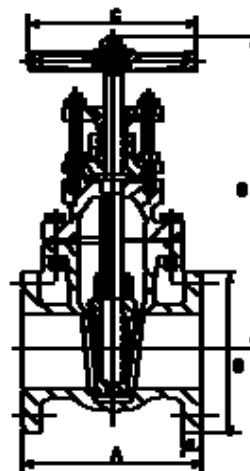
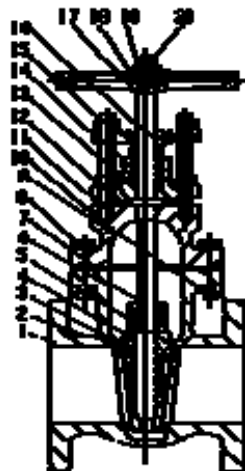

### Materials list

NO.	Part name	Material	American Standard
1.	Body	Cast Iron	ASTM A126 Class B
2.	Seat Ring	Cast Bronze	ASTM B62
3.	Wedge Face	Cast Bronze	ASTM B62
4.	Wedge	Cast Iron	ASTM A126 Class B
5.	Wedge	Cast Bronze	ASTM B62
6.	Stem	Brass	ASTM B16
7.	Body Gasket	Graphite	Non Asbestos



8. Bolts	Steel	ASTM A307-B
9. Nuts	Steel	ASTM A307-B
10. Bonnet	Cast Iron	ASTM A126 Class B
11. Gland Follower Gasket	Steel	ASTM A307-B
12. Stuffing Box Gasket	Graphite	Non Asbestos
13. Stuffing Box	Cast Iron	ASTM A126 Class B
14. Packing	Graphite	Non Asbestos
15. Gland Follower	Ductile Iron	ASTM A536 65-45-12
16. Packing Gland	Cast Brass	ASTM B584
17. Hand wheel	Cast Iron	ASTM A126 Class B
18. Identification Plate	Aluminum	Commercial
19. Washer	Steel	ASTM A307-B
20. Hand Wheel	Steel	ASTM A307-B

### Dimensions (inch&mm)

size	2	2 1/2	3	4	5	6	8	10	12	14	16	18	20	24	30	36
	50	65	80	100	125	150	200	250	300	350	400	450	500	600	750	900
A	7	7 1/2	8	9	10	10 1/2	11 1/2	13	14	15	16	17	18	20	24	28
	177.8	190	203.2	228.6	254	266.7	292.1	30.2	255.6	381	406.4	431.8	457.2	508	609.2	711.2
B	11	12 1/2	13 1/8	15 1/4	17 13/16	19 3/4	25	28 15/16	3 47/16	37	42 1/2	46 1/4	54 5/16	57 1/2	84 1/4	92 1/8
	280	318	333	387	453	502	635	735	875	940	1080	1180	1380	1460	2140	2340
C	7	7	8	10	12	12	13 1/16	16	18	20	22	24	24	30	30	30
	178	178	200	254	300	300	348	400	457	508	558	610	610	762	762	762
D	6	7	7 1/2	9	10	11	13 1/2	16	19	21	23 1/2	25	27 1/2	32	38 3/4	46
	152	178	190	229	254	279.4	343	406	483	533	597	635	699	813	984	1168
E	5/8	11/16	3/4	15/16	15/16	1	1 1/8	13/16	1 1/4	13/8	16/17	19/16	111/16	17/8	21/8	23/8
	15.9	17.5	19.1	23.8	23.8	25.4	28.6	30.2	31.8	35.0	36.6	39.7	42.9	50	54.0	60.4

### Air Conditioner Forging Gate Valve (All Brass)

**Specification:**

**Nominal Pressure :1.6Mpa**

**Working Medium: Water,oil,gas**

**Working Temperature: under 100C**

**Parallel Pipe Thread to GB8464**

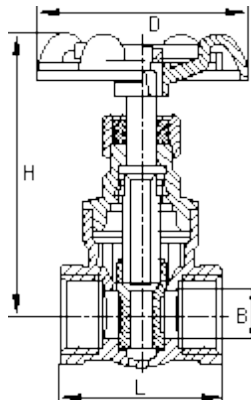



### Dimension of Forging Gate Valve

Size	L	B	H	D
15 1/2"	41	12	73	53
20 3/4"	45	14	74.5	59
25 1"	49.5	18	86	59
32 1 1/4"	53	25	102	72
40 1 1/2"	61	32	118.5	72
50 2"	67	37	134.5	77

### Flange Gate Valve (Brass Body)

**Specification**

**Nominal Pressure :1.6Mpa**

**Working Medium: Water,oil,gas**

**Working Temperature: under 170C**

**Parallel Pipe Thread to GB8464**

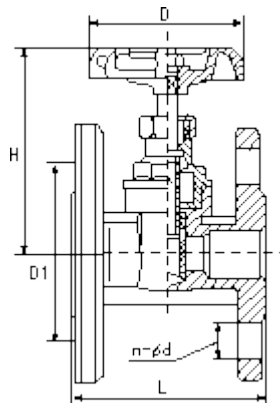

### Dimension of Flange Gate Valve

Size	L	H	D1	D	n-d
DN15	80	80.5	65	60	4-14
DN20	90	87.5	75	60	4-14
DN25	100	98.5	85	60	4-14
DN32	110	120	100	80	4-18
DN40	120	137	110	80	4-18
DN50	120	137	125	110	4-18
DN65	120	169	145	130	4-18
DN80	160	198	160	178	8-18
DN100	180	241	180	200	8-18





## Stainless Steel Forged Gate Valve

### Specification of Gate Valve

Working Pressure :200 PSI WOG

Temperature Range: -20--- 232C

Suitable Medium: Wafer,oil,air and some corrosive liquid

Threaded kinds: NPT. BSPT. BSP.DIN259/2999

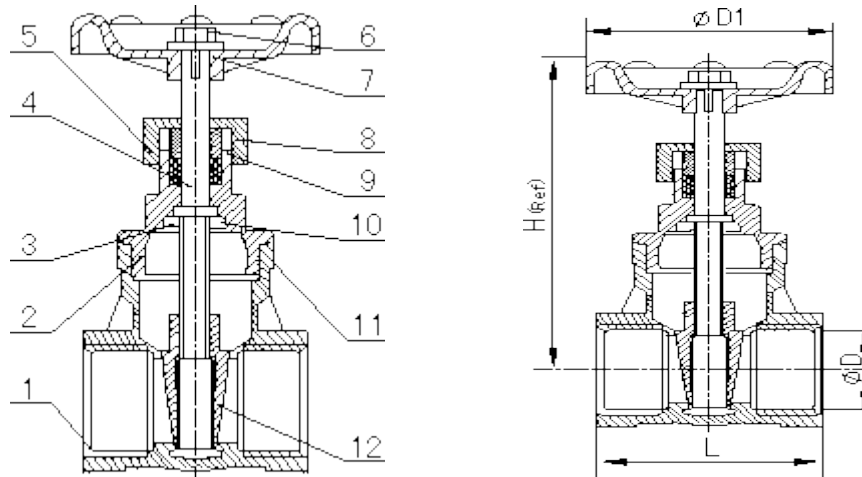

### Main Part and Materials

Item	Designation	Material
1	Body	CF8M
2	Bonnet	CF8M
3	Stop Ring	304
4	Stem	316
5	Packing	R-PTFE
6	Hand wheel Nut	304
7	Hand wheel	Aluminum
8	Packing Nut	316
9	Gland	304
10	Lock Nut	316
11	Gasket	R-PTFE
12	Disc	CF8M

### Dimension of Gate Valve

Size	1/2"	3/4"	1"	1 1/4"	1 1/2"	2"
d	15	20	25	32	40	50
L	55	60	66	76	86	96
H	92	99	113	128	147	168
D1	70	70	80	80	90	100
CV Factor	17.6	32	54	97	135	230



## Flange Gate Valve (Carbon Steel and Stainless Steel)

Design by API Spec.6D and API 600  
 Valves tested by API Spec. 6D and API 598  
 Face to Face by API Spec.6D and ANSI B16.10  
 RF flanged ends by ANSI B16.5 and MSS SP-44  
 Butt-Welding ends by ASME B16.25

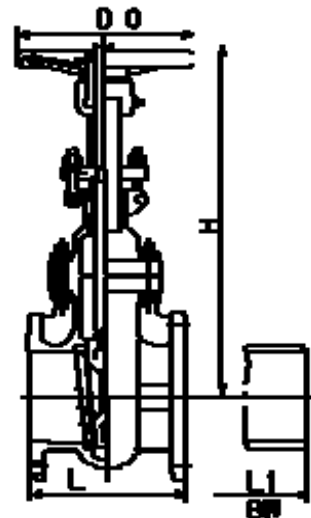
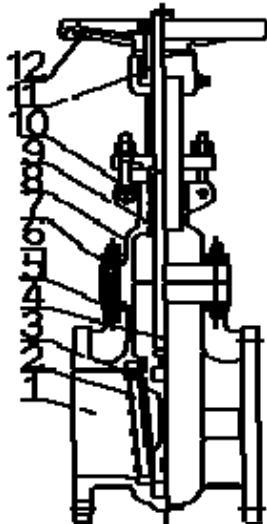

### Part Name

1. Body
2. Seat Ring
3. Wedge
4. Stem
5. Bonnet Bolt
6. Bonnet Nut
7. Gasket
8. Bonnet
9. Backseat Bushing
10. Packing
11. Stem Nut
12. Hand wheel

### Main overall & connection dimension and weight(ANSI Class 150Lb)

NPs	L(RF)		L1(BW)		H(Open)		DO		Weight(RF)		Weight(BW)		
	Inch	mm	inch	mm	inch	mm	inch	mm	lbs	kg	lbs	kg	
2	50	7	178	8-1/2	216	15-3/4	400	8	200	40	18	33	15
2 1/2	65	7 1/2	191	9-1/2	241	19-1/4	490	8	200	62	28	48	22
3	80	8	203	11-1/8	283	20	510	10	250	66	30	57	26
4	100	9	229	12	305	23	585	12	300	110	50	88	40
6	150	10 1/2	267	15-7/8	403	31-1/4	795	14	350	87	85	170	77
8	200	11 1/2	292	16-1/2	419	40	1015	14	350	282	128	260	118
10	250	13	330	18	457	48-1/2	1230	16	400	485	220	440	200
12	300	14	356	19-3/4	502	57-7/8	1465	18	450	682	310	638	290
14	350	15	381	33-1/2	572	69-1/8	1755	20	500	990	450	957	435
16	400	16	406	24	610	80	2030	20	500	1210	550	1120	510
18	450	17	432	26	660	87	2210	24	600	1540	700	1430	650
20	500	18	457	28	711	99	2510	30	750	2000	910	1936	880
24	600	20	508	32	813	113-3/8	2880	30	750	2486	130	2420	1100
26	650	22	559	34	864	115-3/8	2930	36	915	3695	1680	3960	1800
28	700	24	610	36	914	124	3150	36	915	4910	2230	4840	2200

30	750	24	610	36	914	126	3200	36	915	6115	2780	5830	2650
32	800	28	711	38	965	135-7/8	3450	40	1000	6295	2860	6490	2950
34	850	30	762	40	1016	141-3/4	3600	40	1000	6710	3050	7150	3250
36	900	28	711	40	1016	147	3735	40	1000	8140	3700	7745	3520

### Main overall & connection dimension and weight (ANSI Class 300Lb)

NPs	DN		L (RF)		L1(BW)		H (Open)		DO		Weight (RF)		Weight (BW)	
	Inch	mm	inch	mm	inch	mm	inch	mm	inch	mm	lbs	kg	lbs	kg
2	50	8-1/2	216	9-1/8	232	18-1/2	470	8	200	53	24	45	20	
2 1/2	65	9-1/2	241	10-1/8	257	20-3/4	525	8	200	97	44	78	35	
3	80	11-1/8	283	11-3/4	298	21	533	10	250	105	48	82	37	
4	100	12	305	12-5/8	321	24	610	12	300	160	73	118	54	
6	150	15-7/8	403	16-1/2	419	33-1/4	845	14	350	320	145	242	110	
8	200	16-1/2	419	17-1/8	435	41-3/8	1050	16	400	498	226	385	174	
10	250	18	457	18-5/8	473	51	1295	18	450	770	350	627	285	
12	300	19-3/4	502	20-3/8	518	63	1600	20	500	1276	580	1090	495	
14	350	30	762	30-5/8	778	72	1830	20	500	1573	715	1355	615	
16	400	33	838	33-5/8	854	80-1/8	2035	24	600	2310	1050	2070	940	
18	450	36	914	36-5/8	930	86-1/2	2195	24	600	2717	1235	2400	1090	
20	500	39	991	39-3/4	1010	97-1/4	2470	30	750	3640	1655	3300	1500	
24	600	45	1143	45-7/8	1165	114-1/4	2900	38	960	5105	2320	4620	2100	
26	650	49	1245	50	1270	122-5/8	3100	38	960	6295	2860	5675	2580	
28	700	53	1346	54	1372	132-1/4	3360	40	1000	7865	3575	7260	3300	
30	750	55	1397	56	1422	143-5/8	3650	40	1000	9305	4230	8800	4000	
32	800	60	1524	61-1/8	1553	145-5/8	3700	50	1250	10060	4572	9570	4350	
34	850	64	1626	65-1/8	1654	147-5/8	3750	50	1250	10670	4850	9925	4510	
36	900	68	1727	69-1/8	1756	149-5/8	3800	60	1500	11530	5240	10730	4895	

## Flange globe and gate valve technical data

### Material Specification

Parts	C	C6	U	UM	R	RM	
Body	A216-WCB	A217-WCB	A315-CF8M	A351-CF8M	A315-CF3	A315-CF3M	
Bonnet	A216-WCB	A217-WC6	A315-CF8M	A315-CF8M	A315-CF3	A351-CF3M	
S&S Facing	A182-F6 or Stellite		Stellite or Hastelloy C				
Stem	A276-410/420		A276-304	A276-316	A276-304L	A276-316L	
gasket	Class150 Class300	Graphite/304	Graphite/304	Graphite/304	Graphite/316	Graphite/304	Graphite/316
B.S Bushing	A276-410/420		A276-304	A276-316	A276-304L	A276-316L	
Lantern	A276-410/420		A276-304	A276-316	A276-304L	A276-316L	
Bonnet Stub	A193-B7	A193-B16	A193-B8				
Bonnet Nut	A194-2H	A194-4	A194-8				
Packing	Graphite or Stainless Steel Wire						
Stem Nut	ASTM B62						
Hand wheel	ASTM A536						
Note	Equipped with back seat bushing expect Class 150 and 300 Stainless steel Valves						

### Pressure Test By API 6D Specifications

Valve Pressure Class	Minimum Test Pressure, Psig		Pressure Backseat, Psig		Air Seat Psig
	Shell Hydrostatic	Seat Hydrostatic	High (min)	Low (-10,+10)	-10,+10
150	425	300	300	80	80
300	1100	800	800	80	80

### Pressure Test By API 598 Specifications

Valve Pressure Class	Minimum Test Pressure, Psig		Pressure Backseat, Psig		Air Seat Psig
	Shell Hydrostatic	Seat Hydrostatic	High (min)	Low (-10,+10)	-10,+10
150	425	315	315	60----100	80
300	1125	815	815	60----100	80

## CAST IRON GLOBE VALVE FLANGED ENDS

### Description

1. Conforms to Bs 5152
2. Flanges drilled to BS4504
3. Face to face dimensions conform to BS5152 Series 2
4. Working pressure:125S,200WOG
5. Suitable media,water,oil,gas

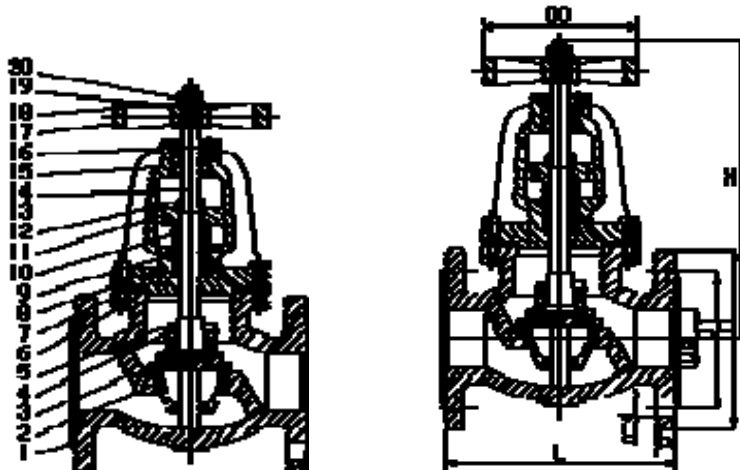

### Materials list of casting iron globe valve

NO.	Part	Material	American Standard
1	Body	Cast Iron	ASTM A126 Class B
2	Seat Ring	Cast Bronze	ASTM B62
3	Disc	Cast Bronze	ASTM B62
4	Gasket	Brass	ASTM B16
5	Swivel Nut	Cast Brass	ASTM B584
6	Bolts	Steel	ASTM A307-B
7	Body Gasket	Graphite	Non Asbestos
8	Bonnet	Cast Iron	ASTM A126 Class B



9	Packing	Graphite	Non Asbestos
10	Packing Gland	Cast Brass	ASTM B584
11	Gland Follower	Ductile Iron	ASTM A536 65-45-12
12	Gland Bolts	Steel	ASTM A307-B
13	Nuts	Steel	ASTM A307-B
14	Stem	Brass	ASTM B16
15	Yoke Bushing	Cast Brass	ASTM B62
16	Screws	Steel	ASTM B584
17	Hand Wheel	Cast Iron	ASTM A126 Class B
18	Identification Plate	Aluminum	Commercial
19	Washer	Steel	ASTM A307-B
20	Nut	Steel	ASTM A307-B

### Dimension (inch&mm)

DIM	2	2 1/2	3	4	5	6	8	10	12
L	8 203.2	8 1/2 215.9	9 1/2 241.3	11 1/2 292.1	13 330.2	14 355.6	19 1/2 495.8	24 1/2 622.3	27 1/2 698.5
D	6 152	7 178	7 1/2 190	9 228.6	10 254	11 279.4	13 1/2 343	16 406	19 483
D1	4 3/4 121	5 1/2 140	6 152.5	7 1/2 190.5	8 1/2 215.9	9 1/2 241.3	11 3/4 298.5	14 1/2 362	17 432
b	5/8 15.9	11/16 17.5	3/4 19	15/16 23.8	15/16 23.8	1 25.4	1 1/8 28.6	1 3/16 30.2	41 1/4 31.8
n-d	4-3/4 4-19	4-3/4 4-19	4-3/4 4-19	8-3/4 8-19	8-7/8 8-22.2	8-7/8 8-22.2	8-7/8 8-22.2	12-1 12-25.4	12-1 12-25.4
D0	7 178	7 178	8 200	10 254	12 300	12 300	13 11/16 348	16 400	18 457
H	10 3/16 259	11 13/16 300	12 1/2 318	15 13/16 402	16 1/2 419	18 7/8 479	21 1/8 537	25 3/16 640	28 7/8 733

## Flange Globe Valve (Carbon Steel and Stainless Steel)

Design by ASME B16.34 and BS5160

Valves tested by API 598

Face to Face by ANSI B16.10

RF flanged ends by ANSI B16.5

Butt-Welding ends by ASME B16.25

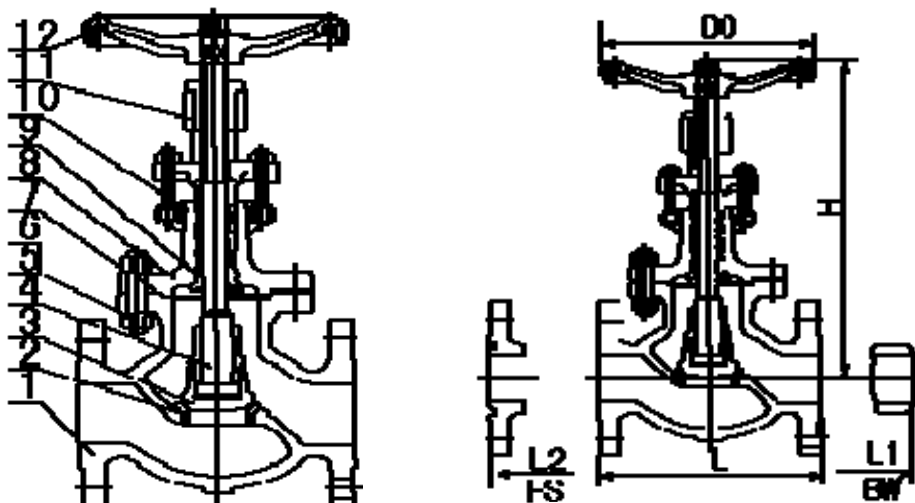

## Part Name

1.Body	4.Stem	7.Gasket	10.Packing
2.Seat Ring	5.Bonnet Bolt	8.Bonnet	11.Stem Nut
3.Disc	6.Bonnet Nut	9.Backseat Bushing	12.Handwheel

## Main overall & connection dimension and weight (ANSI Class 150Lb)

NPs	DN		L/L1(RF/BW)		L2(R&G)		H		DO		Weight (RF)		Weight (BW)	
	Inch	mm	inch	mm	inch	mm	inch	mm	inch	mm	lbs	kg	lbs	kg
2	50	8	203	8-1/2	216	13-1/2	380	8	200	48	22	42	19	
2 1/2	65	8-1/2	216	9	229	15	435	10	250	66	30	60	27	
3	80	9-1/2	241	10	254	17-1/8	465	10	250	82	37	75	34	
4	100	11-1/2	292	12	305	18-1/4	530	12	300	135	61	112	51	
6	150	14	356	14-1/2	368	20-7/8	650	14	350	242	110	194	88	
8	200	19-1/2	495	20	508	25-5/8	760	16	400	370	168	320	146	
10	250	24-1/2	622	25	635	30	860	20	500	524	238	475	215	
12	300	27-1/2	699	28	711	33-7/8	1000	24	600	905	410	815	370	

## Main overall & connection dimension and weight (ANSI Class 300Lb)

NPs	DN		L/L1(RF/BW)		L2(R&G)		H		DO		Weight (RF)		Weight (BW)	
	Inch	mm	inch	mm	inch	mm	inch	mm	inch	mm	lbs	kg	lbs	kg
2	50	10-1/2	267	11-1/8	283	16-1/4	425	8	200	60	27	46	21	
2 1/2	65	11-1/2	292	12-1/8	308	18-3/4	465	10	250	88	40	73	33	
3	80	12-1/2	318	13-1/8	333	20-7/8	530	10	250	115	53	97	44	
4	100	14	356	14-5/8	371	24	610	12	300	175	80	145	66	
6	150	17-1/2	445	18-1/8	460	31-1/8	790	16	400	342	155	282	128	
8	200	21	533	21-5/8	549	34-1/4	870	20	500	528	240	462	210	
10	250	24-1/2	622	25-1/8	638	41	1040	22	550	750	340	620	280	
12	300	28	711	28-5/8	727	44-7/8	1140	24	600	1090	495	900	410	

## Stainless Steel Globe Valve (200 WOG) Specification

Working Pressure: 200PSI WOG

Temperature Range: -20---232C

Suitable Medium : Water, oil, air and some corrosive liquid

Thread kinds: NPT.BSPT.BSP.DIN259/2999

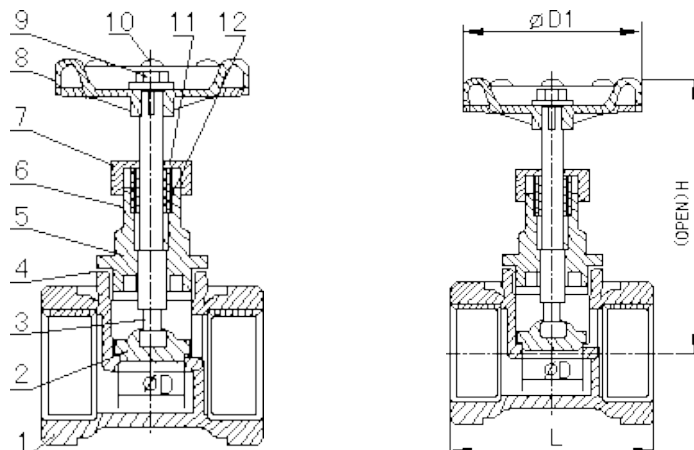

### Main Parts and Materials

Item	Designation	Material
1	Body	CF8/CF8M
2	Petal	CF8/CF8M
3	Stem	316
4	Gasket	PTFE
5	Cap	CF8/CF8M
6	Washer	304/316
7	Gland Ring	CF8M
8	Hand wheel	Aluminum Alloy
9	Nut	304
10	Washer	304/316
11	Ring	304
12	Stem Packing	PTFE

### Brass Flange Globe Valve

#### Specification:

1. Nominal Pressure :1.6Mpa
2. Working Medium: Water,oil,gas
3. Working Temperature: under 150C
4. Parallel Pipe Thread to GB8464

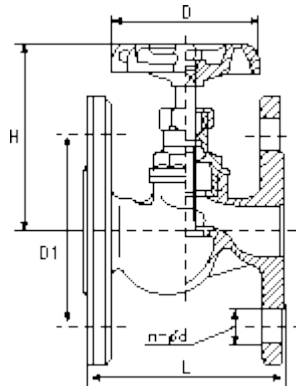

#### Dimension of Flange Globe Valve

Size	L	H	D1	D	n-d
DN15	80	79.5	65	55	4-14
DN20	90	86.5	75	62	4-14
DN25	100	94	85	72	4-14
DN32	110	114	100	80	4-18
DN40	135	132	110	100	4-18
DN50	216	183	125	130	4-18
DN65	236	197	145	180	4-18
DN80	280	275	160	200	8-18
DN100	335	325	180	240	8-18
DN125	400	336	210	240	8-18



DN150	480	379	240	280	8-22
DN200	630	442	295	320	8-22

## Forging Globe Valve (All Brass)

### Specification:

Nominal Pressure :1.6Mpa

Working Medium: Water, oil, gas

Working Temperature: less than 150C

Parallel Pipe Thread to GB8464

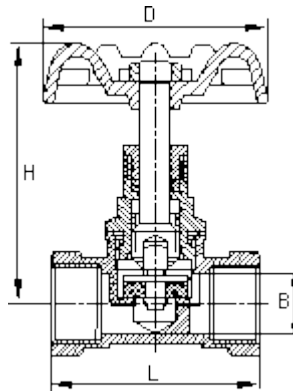

### Dimension of Forging Globe Valve

Size	L	B	H	D
15 1/2"	48	12	69.5	53
20 3/4"	55	17	77	59
25 1"	68	23	94	72
32 1 1/4"	78	27	108.5	77
40 1 1/2"	84	35	129	77
50 2"	108	43	150	96

## Ball Valves

As supplier and manufacturer of best quality ball valves made-in-China, our ball valves are mainly used for high pressure & high temperature services in isolation or combined with other valves. Ball valves has the advantages of wide choices of materials and range of sizes. In addition, generally low torque, low pressure drop and simple valve action are features of ball valves too. For abrasive duties, sterility, coagulating fluids and throttling applications, Other types of valves should be chosen.

A quarter-turn valve with a spherical closing element fixed between two seats.

The characteristics include quick opening and good shut-off. Ball valves are widely used as on/off valves in the chemical processes and other industries. Special designs are available for throttling applications. Larger valves with heavier balls may use trunnions to help support the ball and prevent damage to soft internals. Designs are typically, one, two or three pieces.

Bellows Sealing device prevents lined media leaking between the stem and the body.





## Ball Valve Standard Features:

### ■ Double Block and Bleed:

The fluid entrapped in the valve body is bleedable with the ball in fully closed position to API Spec 6D provisions.

### ■ Valve Bore:

Valve are of full or reduced bore design. Reduced bore is of Venturi type. Minimum bore size is to API 6D requirements.

### ■ Body Structure:

The manufacture of the body is of three types: split-body or welded-body or top-entry. The split or welded body design is used for valve side-entry type. It consists of three forged steel pieces joined by bolting or welding respectively. The body of valve top-entry type is made of one cast steel piece.

### ■ Antistatic Design:

Stainless steel springs ensure the electrical continuity between all the valve metal parts (e.g. body, ball, seat rings and stem) which could be isolated by electrometric or thermoplastic seals.

### ■ Pressure unbalanced ball:

Unless otherwise requested, no hole is provided for the ball to equalize the pressure of the fluid in the pipeline to the one of fluid entrapped in the body cavity when the valve is open. It enables a preventive maintenance, allowing the check of the ball seating efficiency in any valve position, with no modification of the pipeline working condition.

### ■ Anti-blowout stem design:

The stem, detachable from the ball, is blow proofed thanks to an integral abutment resting against the bonnet through a self-lubricating thrust washer.

### ■ Bi-directional seat rings:

Each seat ring is independent floating type and suitably designed to shutoff the fluid aside from its pressure distribution through the valve. So both seat rings constitute a double barrier to the fluid, because of the downstream seat ring ensures shutoff of the fluid in case the upstream one fails. As any overpressure of the fluid entrapped in the valve body cannot be released back into the pipeline, a relief valve is fitted to the vent connection if the handled fluid is a liquid.

### ■ Ball seating:

Valves with rating lower than ANSI Class 1500# have a seat insert made of elastomer to enable double ball sealing: a primary of metal-to-metal and a secondary of soft type (Fig.a). Valves with higher rating are provided with a seat insert made of thermoplastic resin (like Nylon or filled PTFE) to ensure a soft bubble-tight only against the ball (Fig.b). In addition, a double plastic+elastomer seal is recommended for valves having a stainless steel trim with no plating to be used in very low pressure service (Fig.c).

### ■ Double Seal of stem:

Two elastomeric O-rings provided with backup in **PTFE** perform a double stem barrier to the fluid. The outer O-ring can be replaced with the valve under pressure.



### Air Valve Forging Brass Ball Valve

- Technical Standard
- Nominal Pressure: 1.6Mpa
- Working Medium: Water, Oil, Gas
- Working Temperature: under 100C
- Parallel Pipe Thread to GB8486

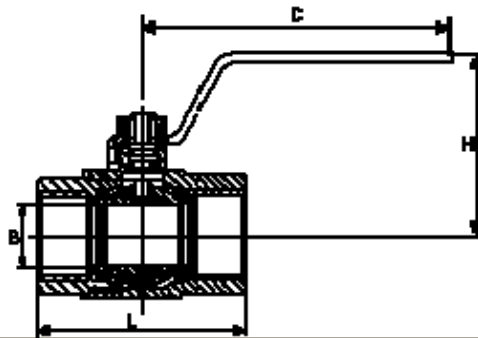

DN	Size	L	B	H	D
15	1/2"	54	12	44	85
20	3/4"	63	15	48	92
25	1"	69	19	54	92
32	1-1/4"	77	25	65	138
40	1-1/2"	84	29	68	138
50	2"	95	40	76	138

### Forging brass ball valve

#### Technical standard

- Nominal Pressure: 1.6Mpa
- Working Medium: Water, Oil, Gas
- Working Temperature: under 100C
- Parallel Pipe Thread to GB8464

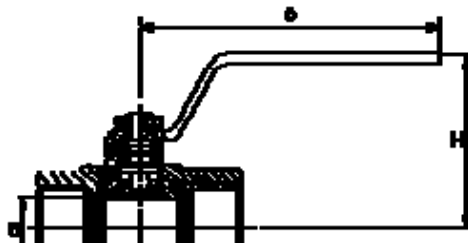

DN	Size	L	B	H	D
15	1/2"	50	12	44	85
20	3/4"	58	15	48	92
25	1"	69	20	54	105
32	1-1/4"	80	25	65	138
40	1-1/2"	90	29	68	138
50	2"	102	40	76	150



65	2-1/2"	123	47	120	230
80	3"	135	57	127	230
100	4"	160	75	137	250

## New Style Forging Brass Valve

### Technical Standard

- Nominal Pressure: 2.0Mpa
- Working Medium: Water, Oil, Gas
- Working Temperature: under 120
- Parallel Pipe Thread to GB8464

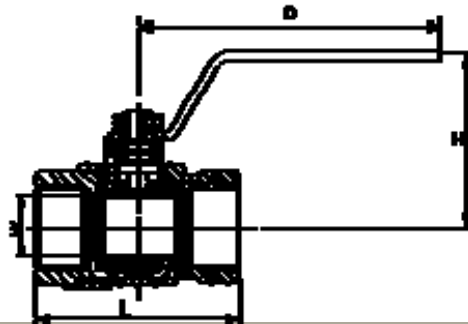

DN	Size	L	B	H	D
15	1/2"	60	15	45	92
20	3/4"	66	19	53	105
25	1"	73	23	56	105
32	1-1/4"	77	25	65	138
40	1-1/2"	84	29	68	138
50	2"	95	40	76	138

## Two Piece Flanged Full Port Ball Valve

Full port construction improves flow characteristics for greater process efficiencies

Blow-Out-Proof Stem: Stem is bottom loaded to prevent removal when valve is in service

Locking Device: Enables plant personnel to secure valve in open or closed position when manually operated

Live-Loaded Stem Packing: Provides constant load on the stem seal and extends service life

Corrosion Resistant: Made of 316 stainless steel for greater chemical resistance and longer service life.

### Specification:

- Working Pressure: 1000PSI WOG
- Suitable Temperature: -20---232C
- Suitable medium: water, oil, gas and some corrosive liquid.

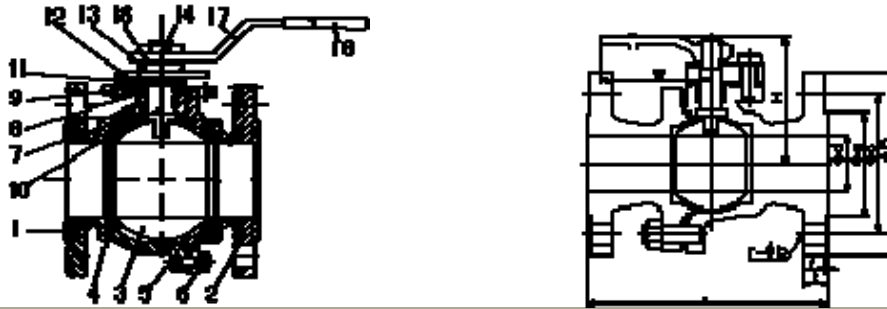

No.	Part Name	Material
1	Body	CF8M
2	Cap	CF8M
3	Ball	SS316
4	Seat	PTFE
5	Body Seal	SS304
6	Bolt& Washer	SS304
7	Thrust Washer	PTFE
8	Stem Packing set	SS304
9	Packing Gland	SS316
10	Stem	SS304
11	Belleville Washer	SS304
12	Stop Plate	SS304
13	Gland Nut	SS304
14	Handle Nut	SS304
15	Position Pin	SS304
16	Gland Nut Lock Washer	SS304
17	Handle	SS304

### Dimension of ball valve

Size	d	W	H	g	f	L	D	C	n	h	t
1/2"	15	130	78	35	2	140	95	66.5	4	16	14.0
3/4"	20	130	88	43	2	152	117	82.5	4	20	16.0
1"	25	160	95	50.8	2	165	125	89	4	20	17.5
1-1/4"	32	225	95	63.5	2	178	135	98.5	4	20	19.5
1-1/2"	38	225	105	73.	2	190	155	114.5	4	22	21.0
2"	51	225	120	92.1	2	216	165	127.5	8	22	22.5
2-1/2"	65	320	145	104.8	2	241	190	149	8	22	25.5
3"	76	400	150	127	2	283	210	168.5	8	22	29.0
4"	102	650	180	157.2	2	305	255	200	8	22	32.0

### Full Port three-pieces flange ball valve

#### Specifications:

- Working Pressure:1000PSI WOG
- Temperature Range:-20---232C
- Suitable medium: Water, oil, air and some corrosive liquid

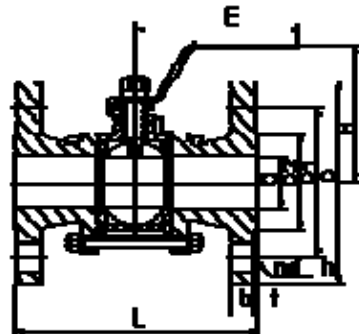
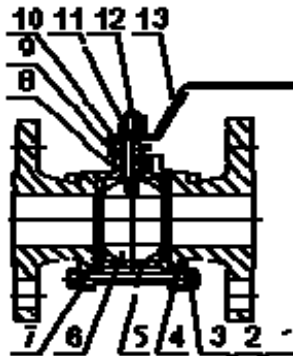

### Main Parts and Materials

NO.	Part Name	Material
1	Bolt	304
2	Washer	304
3	Nut	304
4	Cap	CF8/CF8M
5	Body	CF8M
6	Ball	CF8M
7	Joint Ring	PTFE
8	Stem	316
9	Stem Packing	PTFE
10	Gland Nut	316
11	Washer	304
12	Nut	304
13	Handle	304

### Three-pieces ball valve dimension

Size	d	L	D	D1	D2	b	f	H	W	n-do
1/2"	15	130	95	65	45	14	2	75	130	4-14
3/4"	20	150	105	75	55	16	2	95	140	4-14
1"	25	160	115	85	65	16	2	90	140	4-14
1-1/4"	32	180	135	100	78	18	3	110	170	4-18
1-1/2"	38	200	145	110	85	18	3	130	200	4-18
2"	50	230	160	125	100	20	3	140	220	8-18
2-1/2"	65	290	180	145	120	22	3	170	350	8-18
3"	76	310	195	160	135	24	3	180	350	8-18
4"	100	350	230	190	160	24	3	250	350	8-22

### Reducer one-piece ball valve

- Working Pressure: 1000 PSI WOG
- Temperature Range: -20---232C
- Suitable Medium: Water, oil, air and some corrosive liquid
- Thread kinds: NPT.BSPT.BSP.DIN259/2999

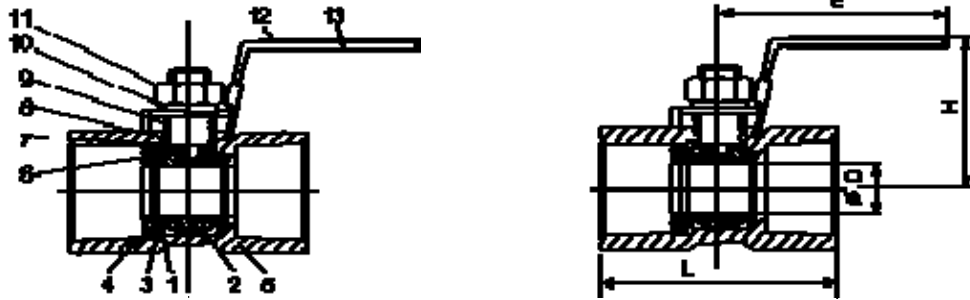

### Main Parts and Materials

NO.	Part Name	Materials
1	Joint Ring	PTFE
2	Ball	SS316
3	Joint Gasket	PTFE
4	Cap	SS316
5	Body	CF8M
6	Stem	SS316
7	Thrust Washer	PTFE
8	Stem Packing	PTFE
9	Gland Nut	SS304
10	Stem Washer	SS304
11	Stem Nut	SS304
12	Handle Cover	Plastic
13	Handle	SS304

### Dimension of ball valve

Size	D	L	H	E
1/4"	5	40	35	64
3/8"	7	45	37	70
1/2"	9.2	56.5	43.5	90
3/4"	12.5	60	47	90
1"	15	72	50	103
1-1/4"	20	78	57	103
1-1/2"	24.5	85	69	127
2"	32	100	74.5	127

### Full Port two-pieces ball valve

- Stem is bottom loaded to prevent removal when valve is in service
- Enables plant personnel to secure valve in open or closed position when manually operated
- Made of 316 stainless steel (CF8M) for superior chemical resistance and longer service life
- Improves dimensional control and reduces porosity
- Actuator mounting pad

### Specification of two pieces ball valve

- Working Pressure: 1000PSI WOG
- Temperature Range: -20--- 232C
- Suitable medium: Water, oil, air and some corrosive liquid.
- Thread kinds: NPT.BSPT.BSP.DIN259/2999

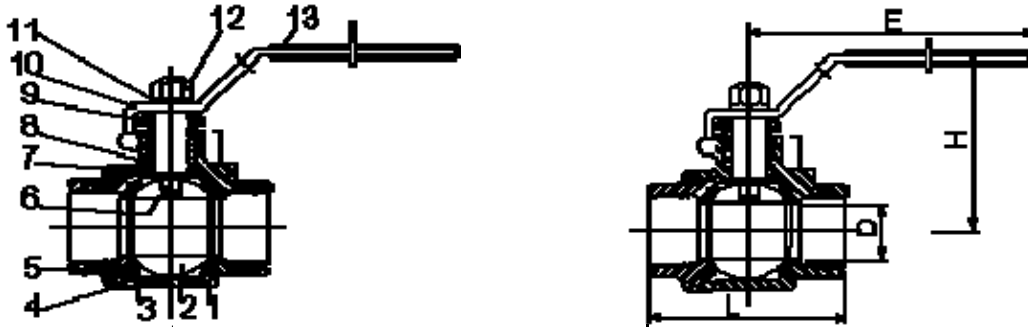

### Main Parts and Material of Ball Valve

No.	Part Name	Material
1	Body	CF8M
2	Ball	SS316
3	Joint Ring	PTFE
4	Joint Gasket	PTFE
5	Cap	CF8M
6	Stem	SS316
7	Thrust Washer	PTFE
8	Stem Packing	PTFE
9	Gland Nut	SS304
10	Handle	SS304
11	Stem Washer	SS304
12	Stem Nut	SS304
13	Handle Cover	Plastic

### Ball Valve Dimension

Size	D	L	H	E
1/4"	11.6	55	50	10
3/8"	12.7	55	50	100
1/2"	15	65	60	130
3/4"	20	75	64	130
1"	25	88	71	165
1-1/4"	32	102	78	165
1-1/2"	38	110	86	190
2"	50	125	95	190
2-1/2"	65	162	130	250
3"	80	189	148	250
4"	100	260	180	280

### Full Port three-pieces ball valve

- Dynamic loading on stem packing ensures a tight seal through varying pressure and temperature conditions, reducing maintenance costs and extending service life
- End Cap Alignment Step: Ensures easy and proper alignment between mating parts
- Full Port Design: Improves flow resulting in increased process efficiencies
- 3-Piece Construction: Easy to repair
- Stem is bottom loaded to prevent removal when valve is in service
- Locking Device: Enables plant personnel to secure valve in open or closed position when manually operated



## Specification of three pieces ball valve

- Working Pressure: 1000PSI WOG
- Temperature Range: -20--- 232C
- Suitable medium: Water, oil, air and some corrosive liquid
- Thread kinds: NPT.BSPT.BSP.Din259/2999

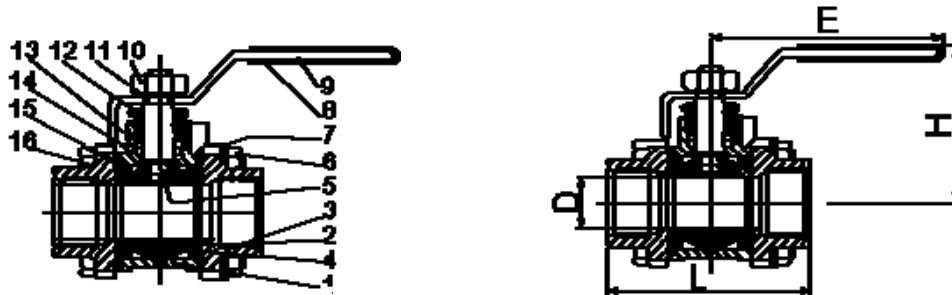

## Main Parts and Materials

NO.	Part Name	Material	
		stainless steel	carbon steel
1	Body	CF8M	WCB
2	Joint Ring	PTFE	PTFE
3	Cap	CF8M	WCB
4	Ball	SS316	SS304
5	Stem	SS316	SS316
6	Nut	SS304	FCD45
7	Washer	SS304	FCD45
8	Handle Cover	Plastic	
9	Handle	SS304	SS304
10	Stem Nut	SS304	B7
11	Stem Washer	SS304	SS304
12	Gland Nut	SS304	FCD45
13	Stem Packing	PTFE	PTFE
14	Thrust Washer	PTFE	PTFE
15	Joint Gasket	PTFE	PTFE
16	Bolt	SS304	B8

## Dimension of Ball Valve

Size	D	L	H	E
1/4"	11.6	68	100	100
3/8"	12.7	68	100	100
1/2"	15	72	130	130
3/4"	20	82	130	130
1"	25	90	165	165
1-1/4"	32	112	165	165
1-1/2"	38	120	190	190
2"	50	145	190	190
2-1/2"	65	185	250	250
3"	80	210	250	250
4"	100	268	280	280