

INJECTION MOLDS FOR PIPE FITTINGS

Gestión de Compras has extensive experience in the design, development and manufacture of plastic injection molds for the production of pipe fittings.

PROCESS:

One major processes used in manufacture plastic pipe fittings is the injection molding. Equipment to mold fittings consists of a mold and an injection molding press.

- The mold is a split metal block (usually steel or stainless steel) that is machined to form the cavities in the block. Hollows in the mold parts are created by tools shaping the part cavity. The molded parts are created by filling the cavity in the mold through a filling port called gate. Depending on the part to be made, an injection mold can be made with multiple cavities and integrated by several gates.

Also this type of parts are generally hollow. Then is important the design of the cores in order to produce an enough quality for internal surfaces, that are very important in the suitability of the pipe fitting.

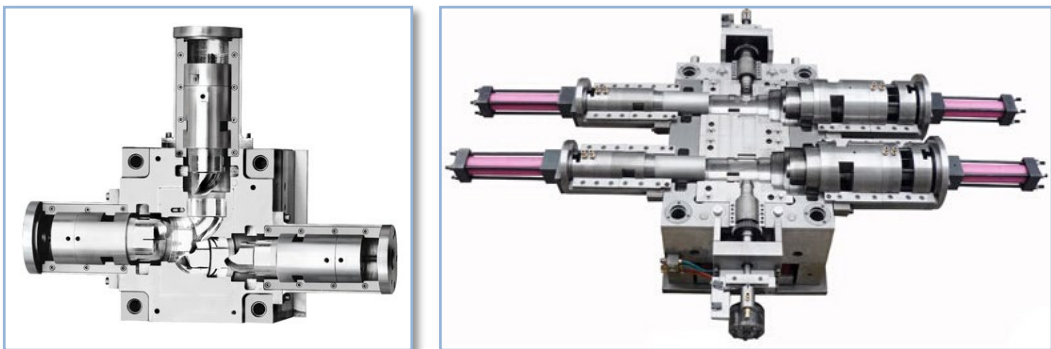

- The injection molding press has two parts, a press to open and close the mold and an injection extruder to inject material into the mold cavity.

When the mold is closed, the melted material is injected into the mold cavities under high pressure then, the mold is cooled by water circulating and when the parts has solidified, the mold is opened and parts are ejected.

PRODUCTION:

Gestión de Compras has extensive experience in the design, development and manufacture of plastic injection molds for the production of pipe fittings. We produce parts in a wide range of sizes and shapes for any application. We manufacture molds according to most demanded standards thus as custom parts for special applications.

MATERIALS AND PRODUCTS:

Plastic injection molds for fittings accepts a huge range of plastic, such as PVC, PP, PE, PB, ABS, POM, PVDF, PPSU...



Fittings that are produced by injection molding are available in various shapes and sizes such as coupler, TEE, reducers, elbows 90° - 45°, crosses, end caps, sockets, adapters, bushings, plugs... And they are used worldwide in sanitary and storm sewer systems, drinking water supply, roof drains, irrigation, drainage, gas supply, ventilation, mining and industrial, communications, electrical, exhaust systems, etc.

STANDARD AND CERTIFICATES:

In **Gestión de Compras** we ensure that our suppliers are holders of the most demanded certificates, such as:

- **ISO 9001**
- **ISO 14001**
- **OHSAS 18001**



CONTACT:

In **Gestión de Compras** work with a wide range of customers from different sectors but have in common the search for products that suit your needs at the best Price and the guaranteed maximum quality. Check with us about any product. We have a qualified staff who will advise you.

C/ Marzo, 9

02002 Albacete (Spain)

Phone: + (34) 967 221 602

Fax: + (34) 967 223 369

Email: info@gestiondecompras.com



Productos

